



Qudelix-5K DAC/AMP

User's Guide



JAN 2023

Copyright ©2023 by Qudelix, Inc. All rights reserved.

Key Specification

- **Bluetooth 5.0**
 - Class 2 (2.5mW 4dBm) up to 10m
 - 2.4GHz
- **Qualcomm QCC5124 Bluetooth Chipset**
- **Dual ES9219 SABRE HiFi® DAC**
 - 3.5mm output works with single DAC only.
 - Dual DAC is available with 2.5mm output.
- **High Precision MEMS Audio Clock**
- **aptX Adaptive, LDAC, AAC, aptX-HD, aptX, SBC**
- **High-Resolution USB DAC 96KHz / 24-bit**
 - USB Audio Class 1.0
 - Windows/MacOS/Linux (No Device Driver)
 - Android Device through C-to-C or OTG cable
- **20-band Double Precision GEQ/PEQ**
- **10-band Left/Right Independent GEQ/PEQ**
- **High Sensitivity 3-D LDS (Laser Direct Structuring) Antenna**
 - Bluetooth Range more than 10 meters
- **Qualcomm® cVc™ noise cancellation technology**
- **High Sensitivity MEMS Microphone**
- **Four Multi-functional Buttons & Two LEDs**
- **Companion Mobile app for iOS/Android**
- **Companion Chrome app for PC/MacOS**
- **Over-the-Air firmware update**
- **Material**
 - Plastic Body (Black) with anti-scratch UV Coating
 - Aluminium Clip (Dark Gray)
- **52.8 x 26.7 x 15.6mm (including Clip)**
- **26 grams**



Key Specification

- **Output Power**
 - 3.5mm 80mW per channel
 - 2.5mm 240mW per channel
- **SNR (A-weighted)**
 - 3.5mm -118dB
 - 2.5mm -122dB
- **THD+N**
 - 3.5mm 0.004%
 - 2.5mm 0.002%
- **Separation**
 - 3.5mm 79dB
 - 2.5mm 117dB (1KHz/32-ohm)
- **Output Impedance**
 - Less than 1-ohm



Buttons (with BLUE LED)

Power On/Off (long press 3 sec)

Previous Tack (Double Click)

BL(Blue Lower)

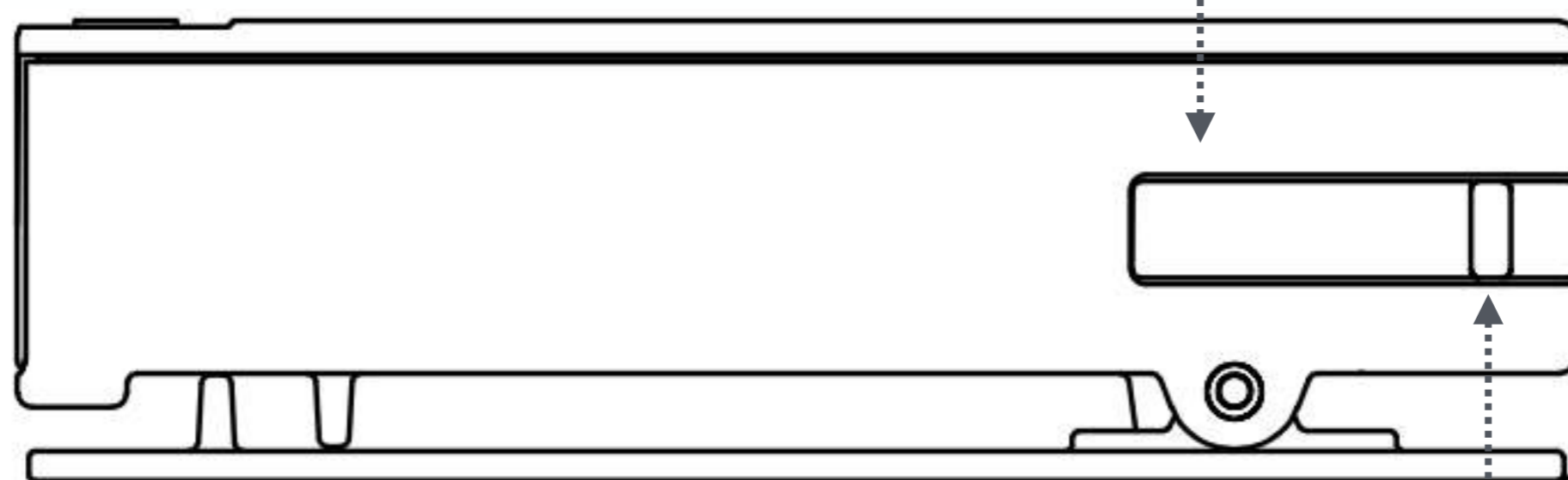

Pairing Mode (long press 3 sec)

Play/Pause (Single Click)

Next Track (Double Click)

Answer Incoming Call (Single Click)

BU(Blue Upper)



Buttons (with RED LED)

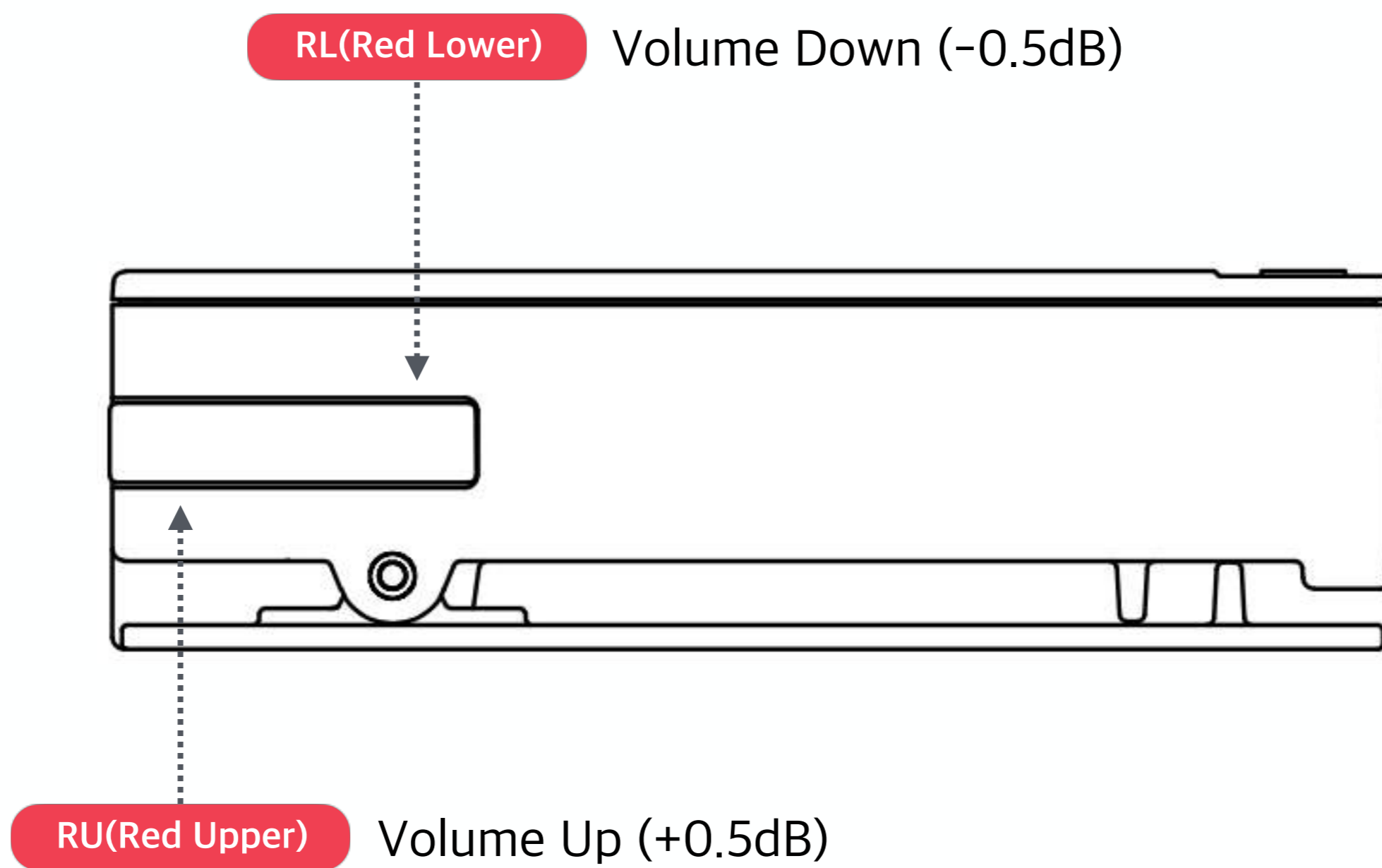

Audio Output & Microphone

2.5mm Balanced Audio Output
Max. 4V RMS (240mWatt/Ch)

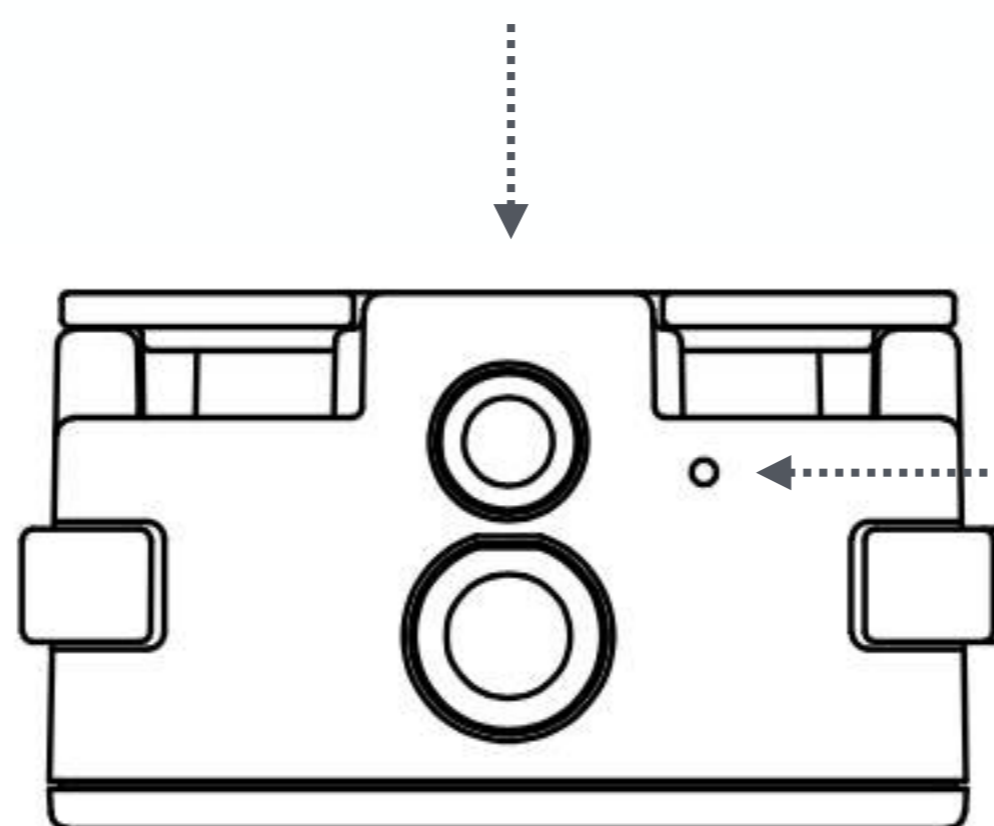

Built-In Microphone

3.5mm Unbalanced Audio Output
Max. 2V RMS (80mWatt/Ch)



Pairing with Android

1. Power On 5K

- Press **BL(Blue Lower)** button for more than 3 sec.

2. Enter Pairing Mode

- Press **BU(Blue Upper)** button for more than 3 sec.
- **Red, Blue** LED blink when pairing mode.

3. Go to the Android Bluetooth menu

- Scan Bluetooth devices.
- Select Qudelix-5K in the Available devices list.
- If Qudelix-5K does not appear, please toggle the Bluetooth button OFF and ON, then try scanning again.

4. Paired

- Once paired successfully, you will see Qudelix-5K in the Paired devices list.

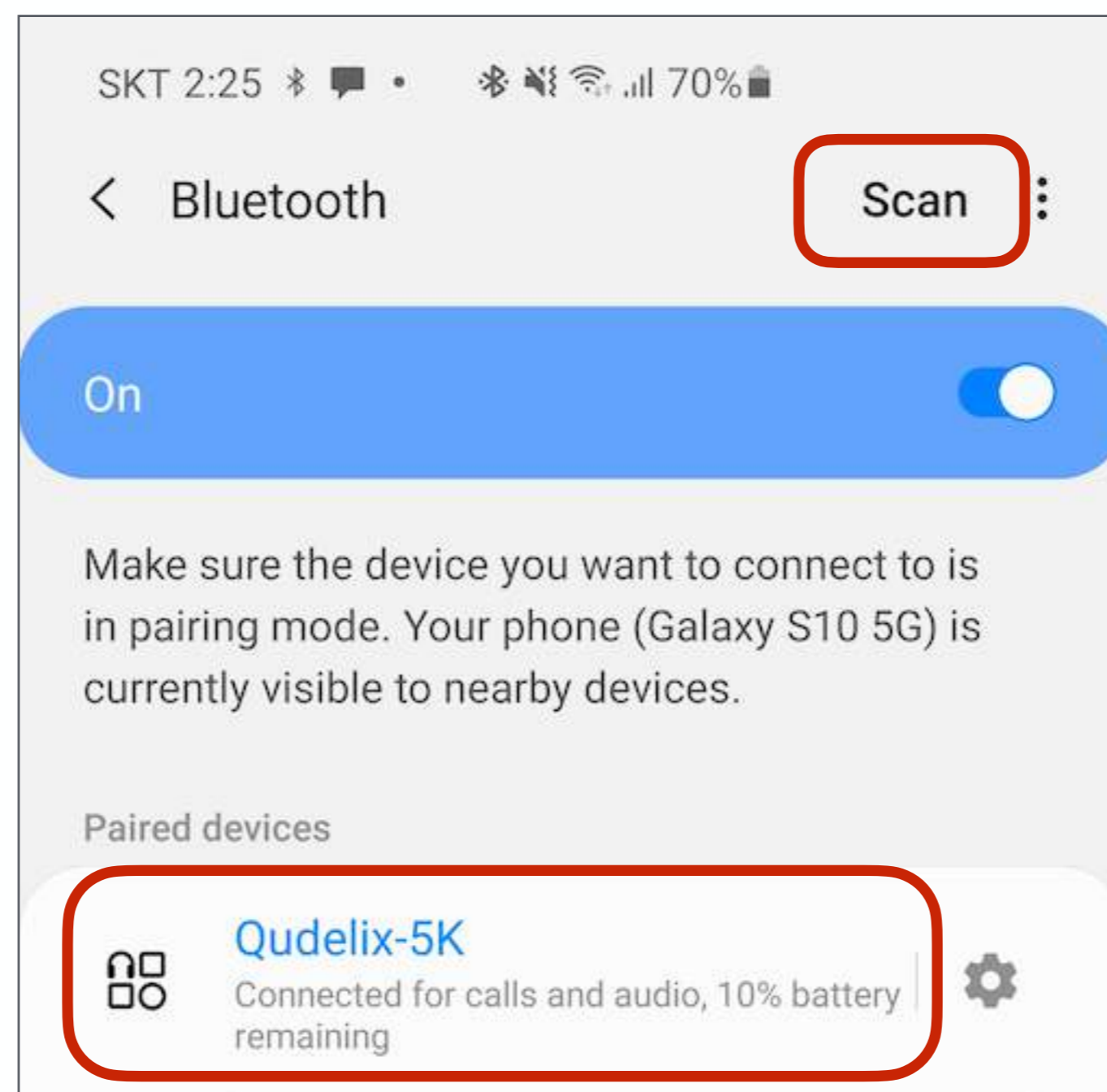

Android - LDAC

- Android 8.0 or higher supports SONY LDAC, a high-quality audio codec.
- After pairing the device with an Android smartphone, please enable LDAC in the Android Bluetooth menu.
 - Go to the paired devices list
 - Select the option button for Qudelix-5K
 - Enable LDAC for high-quality audio streaming

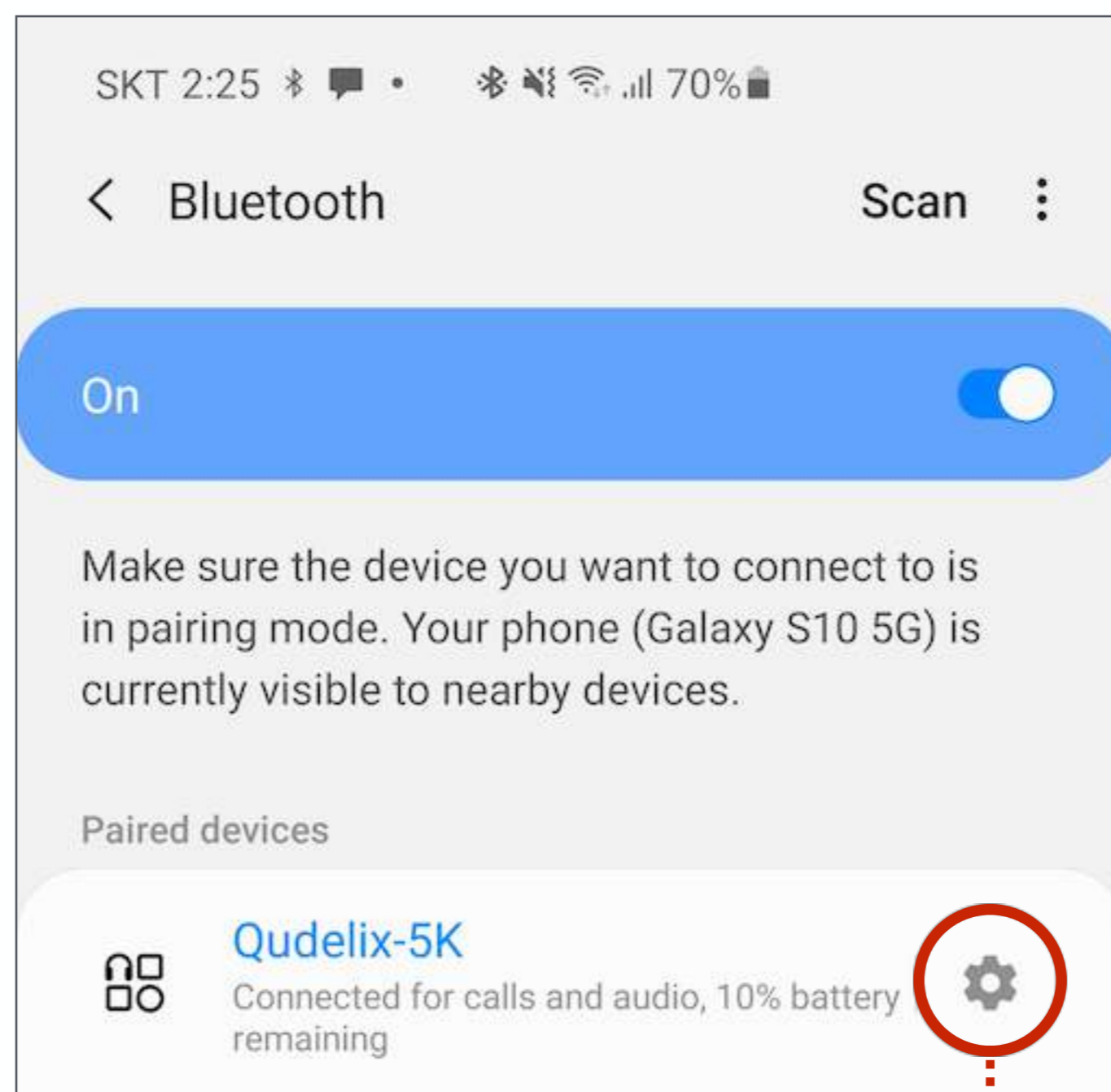

Option Button

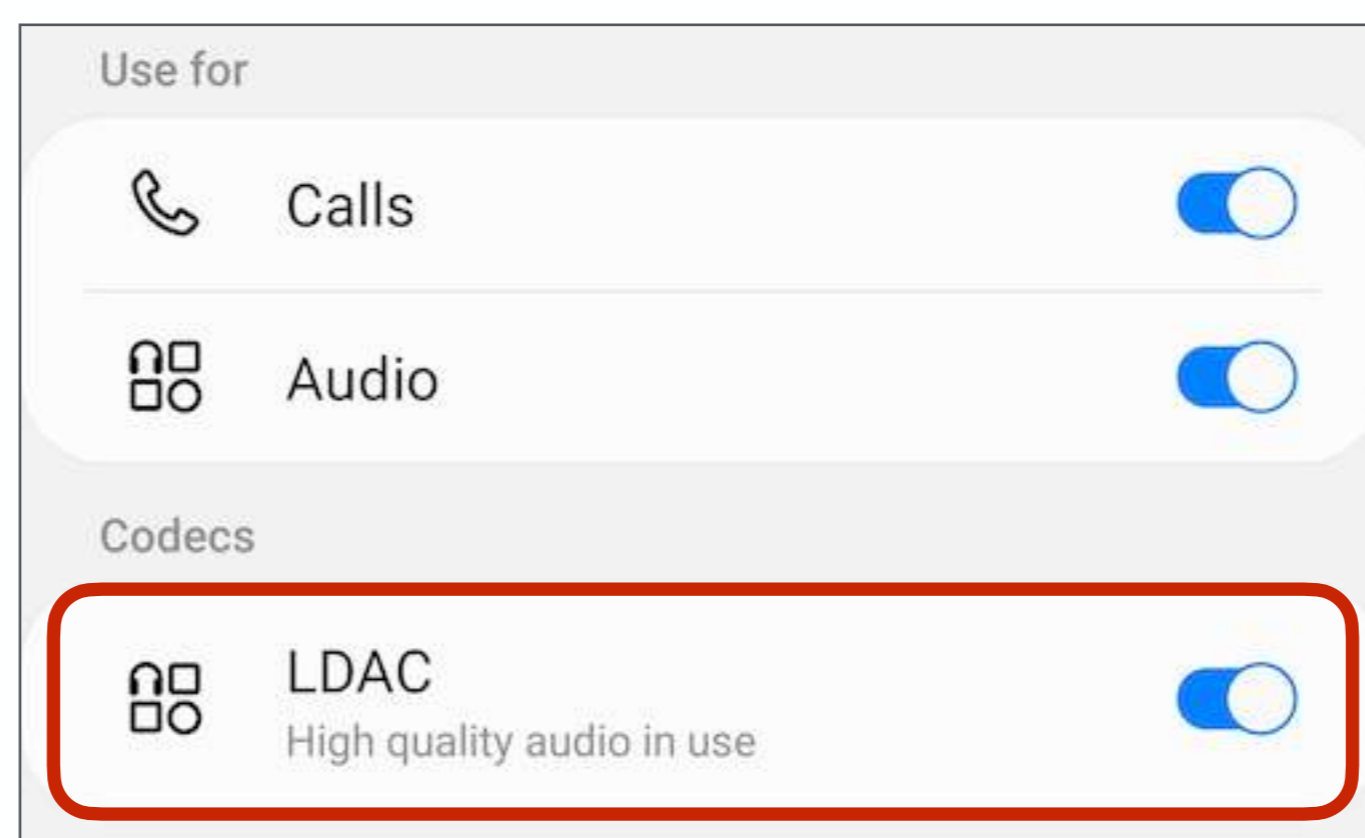

***Enable Sony LDAC after pairing**

Mobile App - Android



- Install Android Mobile App (requires Android 8.0 or higher)
 - https://play.google.com/store/apps/details?id=com.qudelix.qudelix&hl=en_US



- The Qudelix App has nothing to do with Bluetooth Audio Streaming. You can get audio streaming over Bluetooth without Qudelix App. However, we strongly recommend installing and using the app to fully experience the feature-rich nature of Qudelix-5K.
- 5K allows the APP connection with one device at a time.
- Android App uses the BR/EDR link. So, Android requires the 5K device paired to the system before making the app connection.

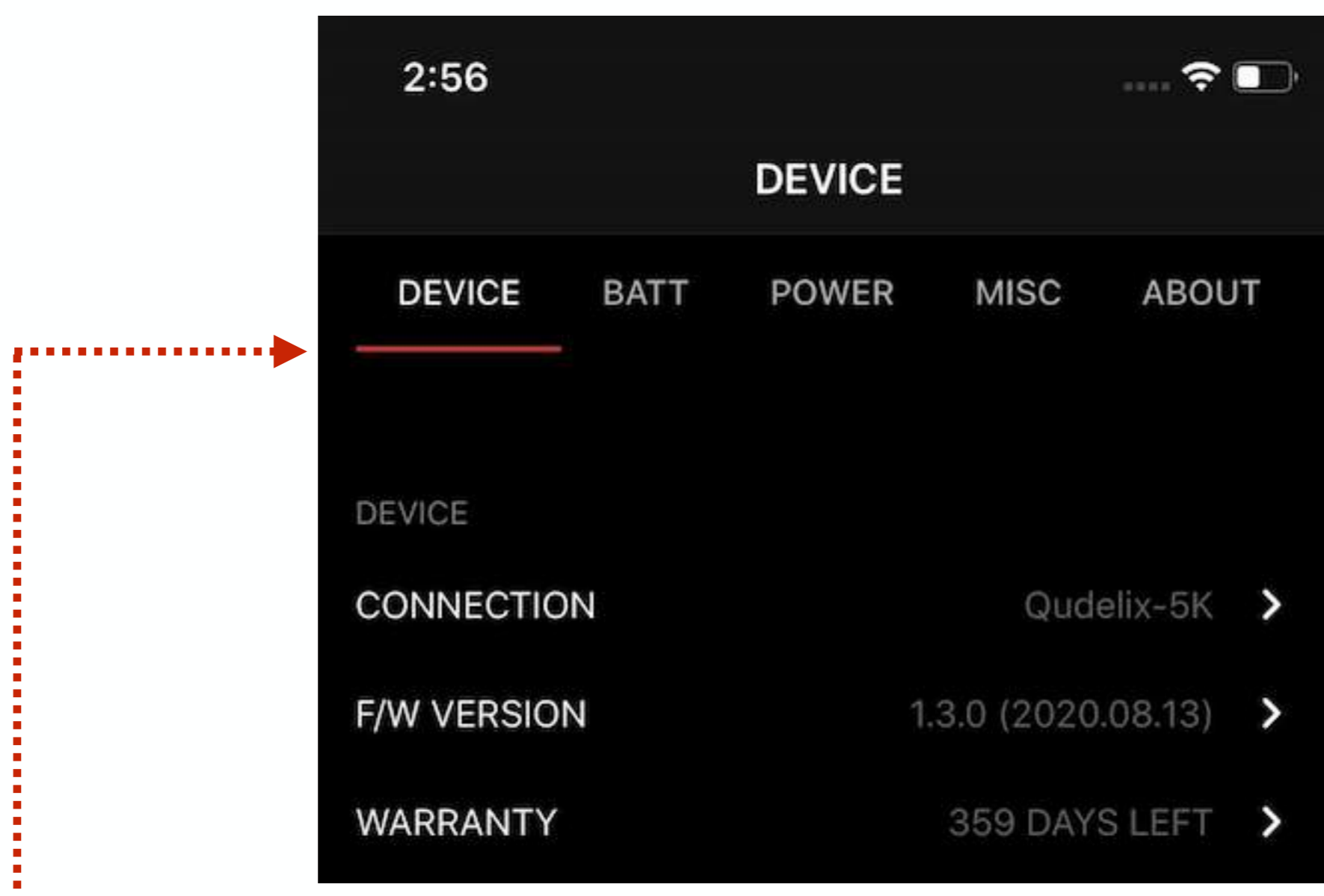

*The Red Bar indicates the app connected to the device; gray otherwise.

Pairing with iOS

1. Power On 5K

- Press **BL(Blue Lower)** button for more than 3 sec.

2. Enter Pairing Mode

- Press **BU(Blue Upper)** button for more than 3 sec.
- **Red, Blue** LED blink when pairing mode.

3. Go to your iOS Bluetooth menu

- Scan Bluetooth devices.
- Select Qudelix-5K in the Available devices list.
- If Qudelix-5K does not appear, please toggle the Bluetooth button OFF and ON, then try scanning again.

4. Paired

- Once paired successfully, you will see **Qudelix-5K Connected** ⓘ in the MY DEVICES list.

Scan and select →



← Connected with ⓘ

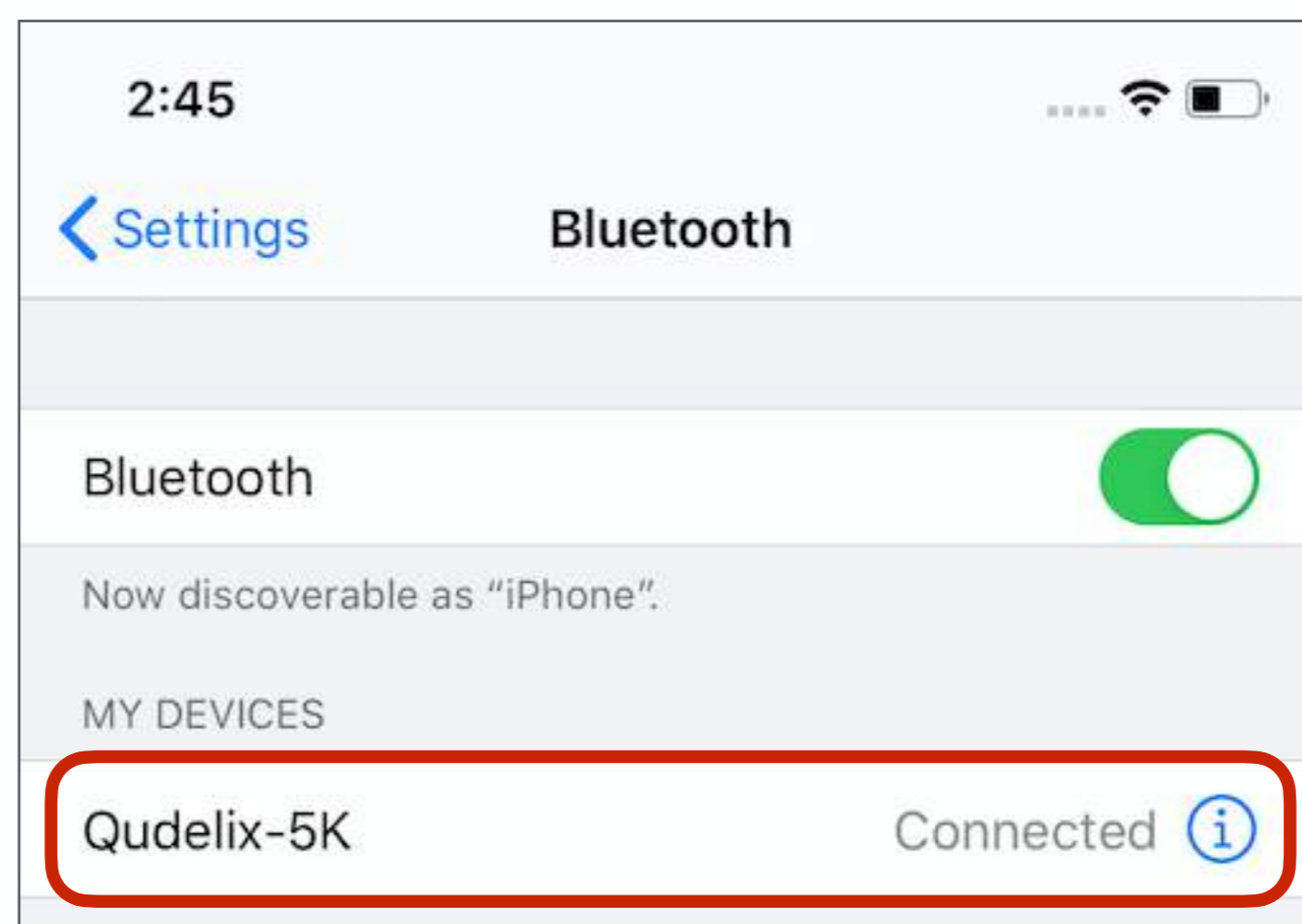

Qudelix 5K Bluetooth Audio Connection

Mobile App - iOS



- Install iOS Mobile App
 - <https://apps.apple.com/kr/app/qudelix/id1515641059?l=en>



- The Qudelix App has nothing to do with Bluetooth Audio Streaming. You can get audio streaming over Bluetooth without Qudelix App. However, we strongly recommend installing and using the app to fully experience the feature-rich nature of Qudelix-5K.
- 5K allows the APP connection with one device at a time.
- iOS App uses the BLE(Bluetooth Low Energy) link.
 - 'Connected ⓘ' represents the Audio/Call connection.
 - 'Connected' represents the app connection over BLE.

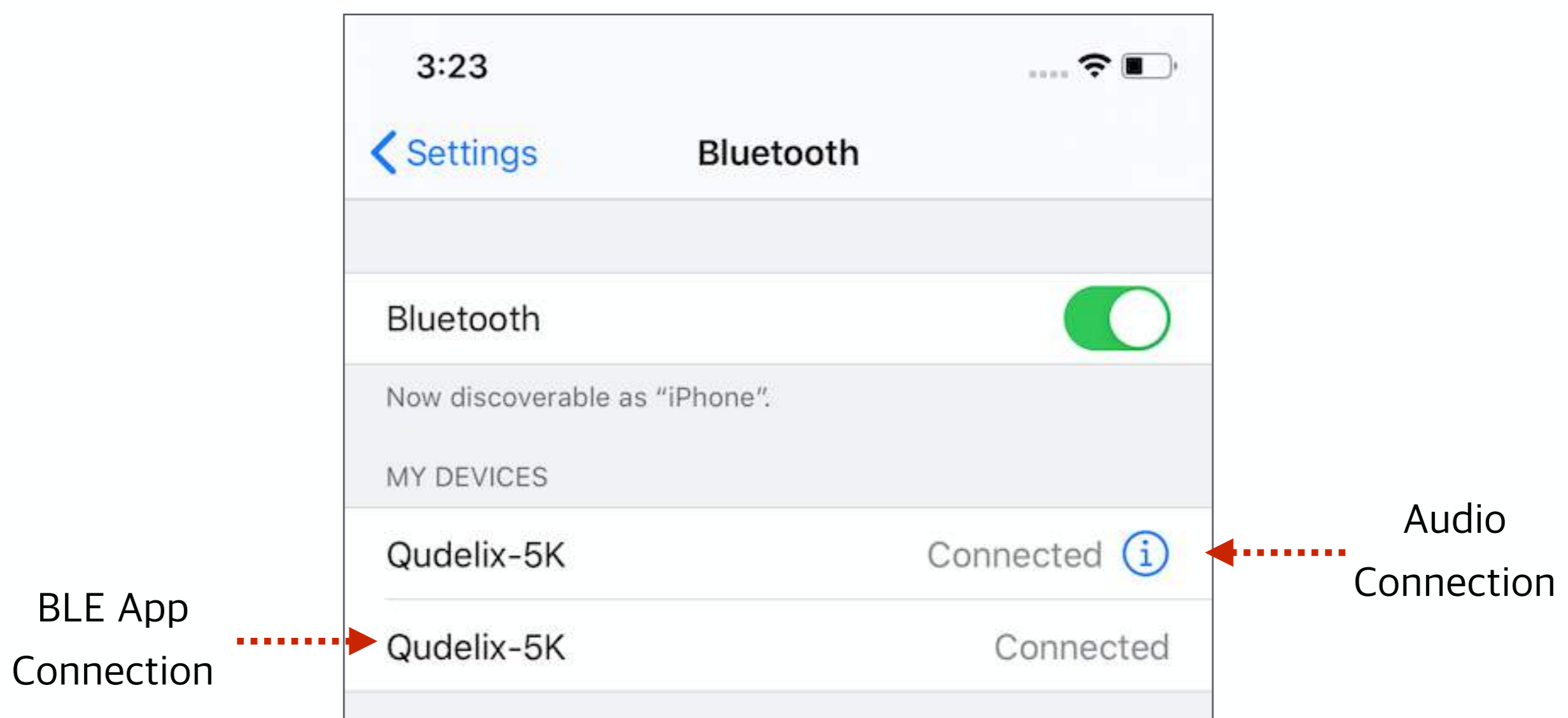

Pairing with Windows

- Do not make the BLE connection when pairing the 5K with a Windows PC.
- When searching for nearby Bluetooth devices in the Windows Bluetooth menu, you will see a Qudelix-5K Audio and a Qudelix-5K.
 - Qudelix-5K Audio (Headset icon) - for Voice Call & Music
 - Qudelix-5K (BLE) - for iOS/Android app connection
- Make the connection to Qudelix-5K Audio (Headset icon) only.
- Connecting the Qudelix-5K (BLE) will cause an iOS/Android app connection failure.

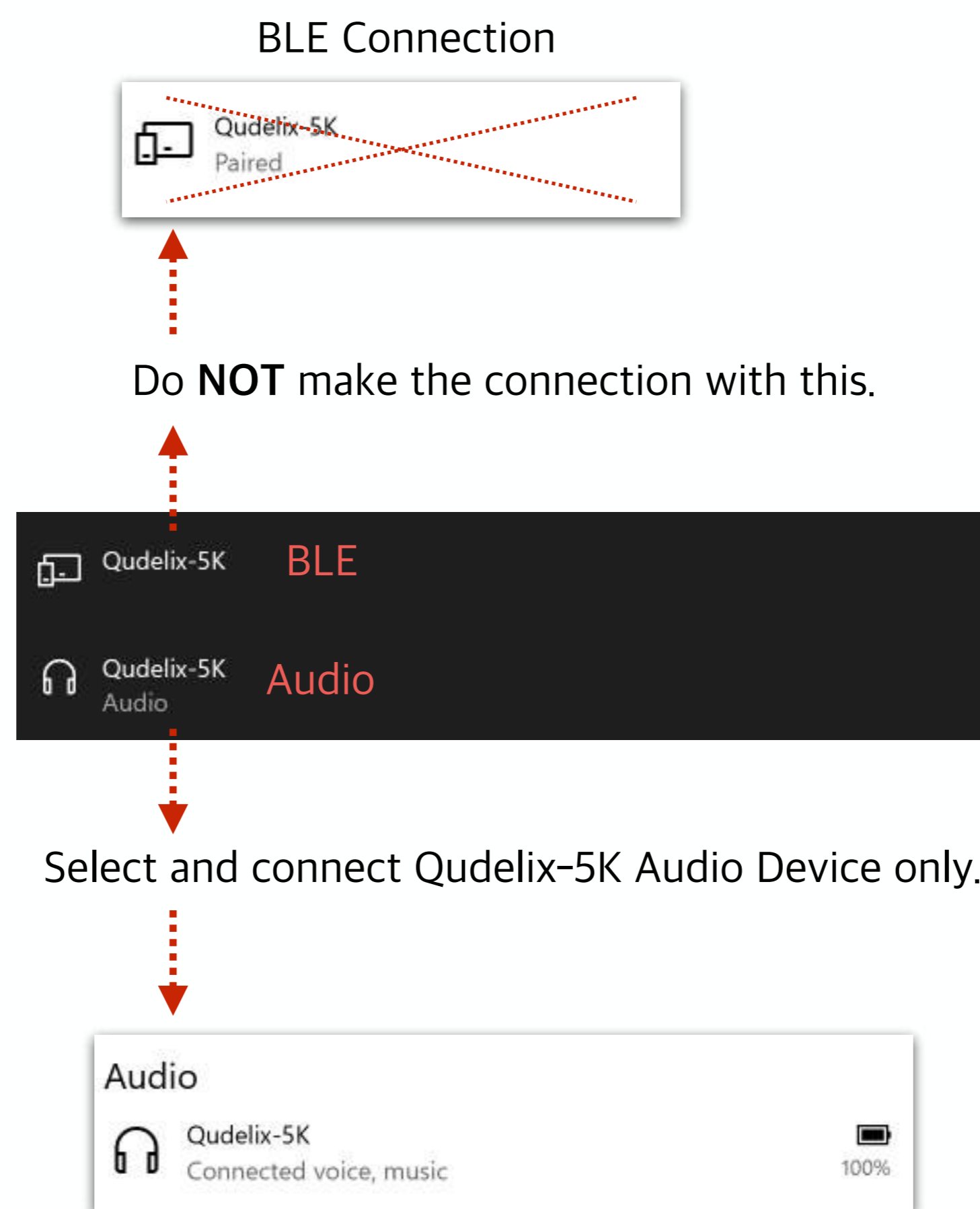

Battery

- The app displays the current battery and charger status.
 - Battery Log Graph
 - Instantaneous battery level
- The battery voltage is just for reference.
- **Use a standard 5V charger or PC USB only. (Do NOT use a high-speed charger)**
 - The 5K built-in charger will limit the maximum charging current to 200mA.
 - 500mA Battery / 2H 30MIN charging time from empty to full

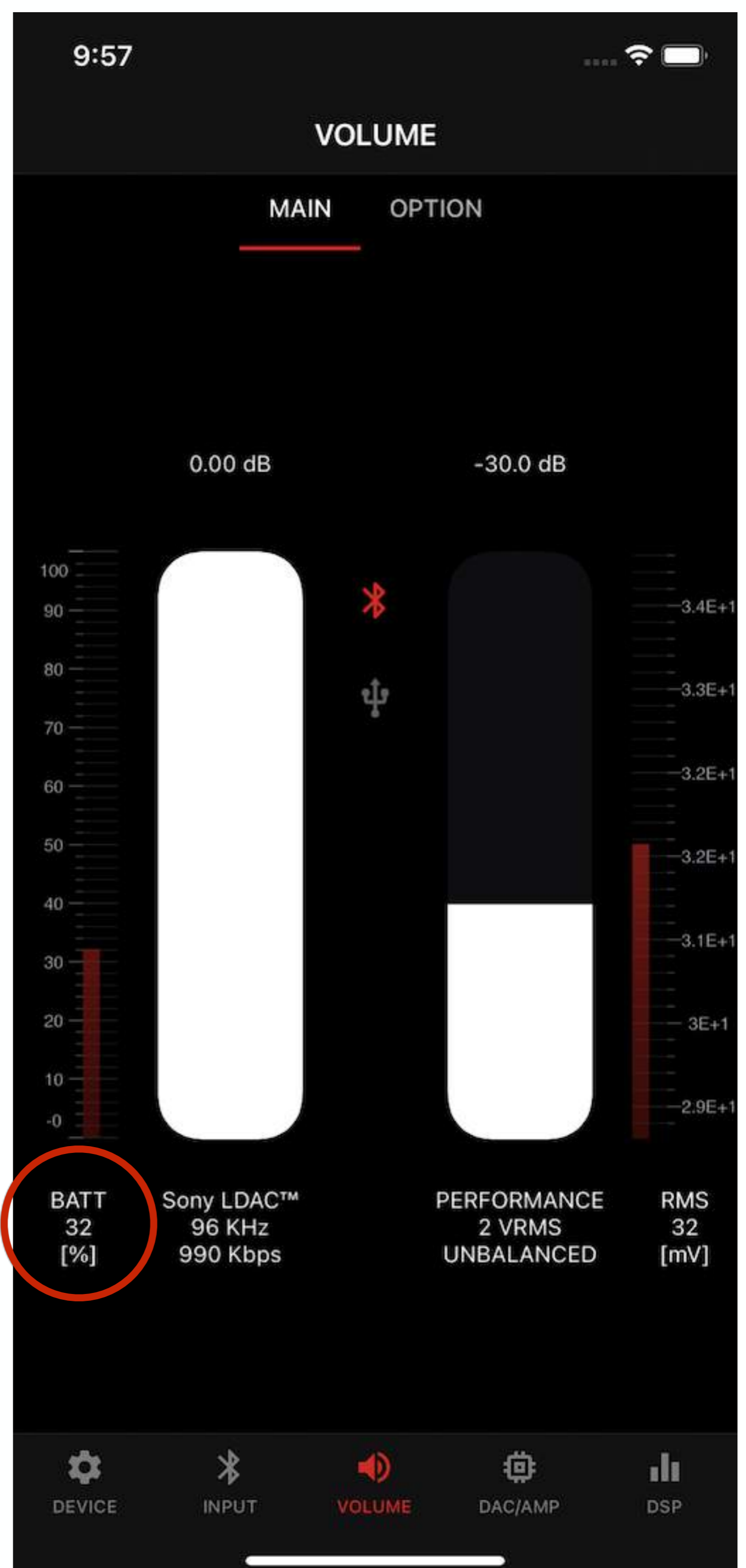
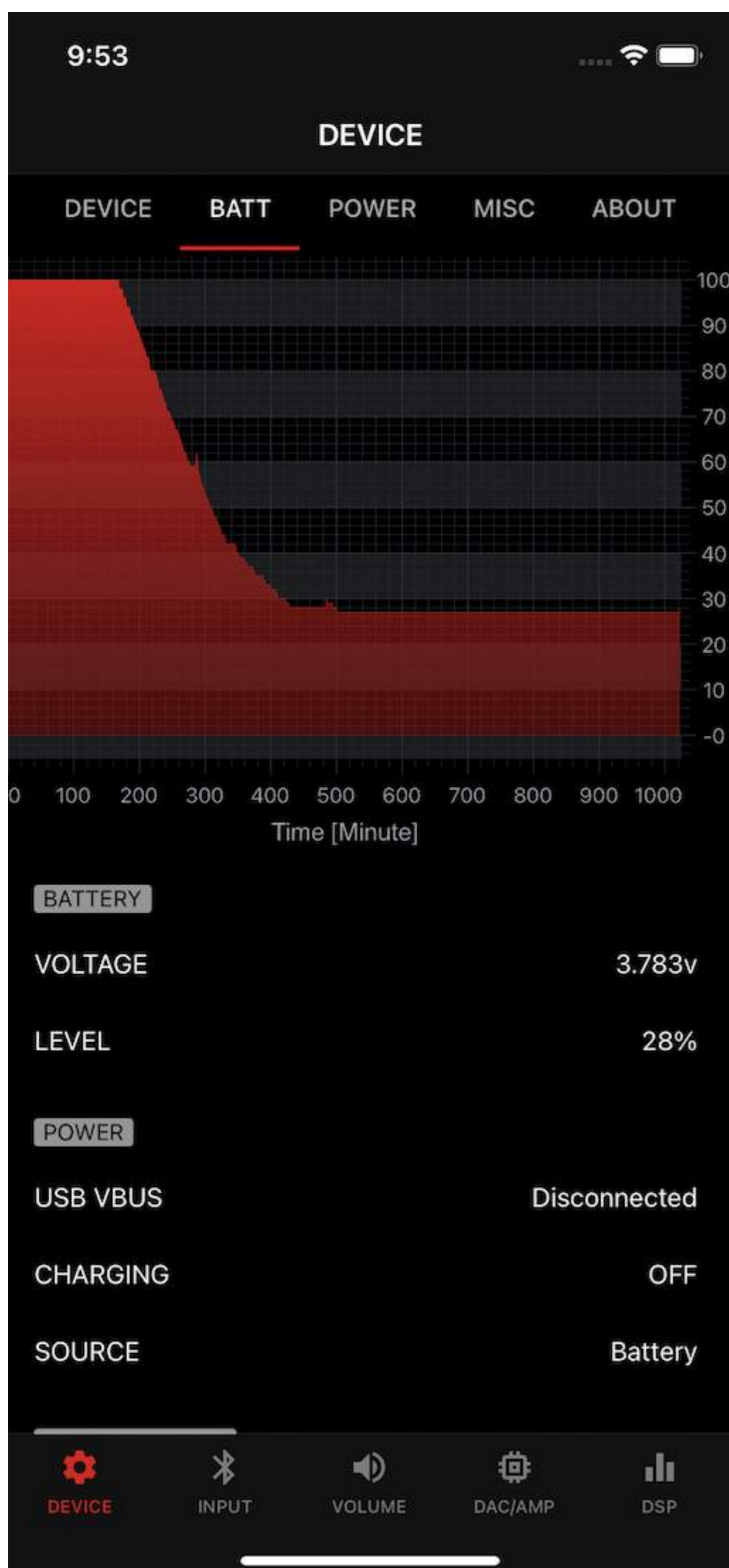

Battery - Safety Warning

- Always remember that heat is the number one enemy of LiPo batteries. The hotter your batteries get, the shorter their lifespan will be.
- Do not leave the battery in a hot temperature environment. Especially for the use case with car aux-in, do not leave the 5K in a car. The average temperature inside a vehicle could reach nearly 120 ~160 degrees Fahrenheit. It would kill the battery life and cause the battery to be in serious FIRE HAZARD.
- A 5V(1~2A) standard charger or PC USB port may prevent HW damage by accidental high voltage.
- If improperly used, Rechargeable Lithium-ion Polymer batteries are potentially hazardous and can present a severe FIRE HAZARD, SERIOUS INJURY, and PROPERTY DAMAGE.



Battery Time

- Please note that the battery times may differ across each use case.
 - The battery time varies across the codec, sample rate, power profile, and output mode.
 - The sensitivity of the earphones/headphones and the output volume level also can make the battery time longer or shorter.

AAC 44.1KHz

	Standard Mode		Performance Mode	
	Current Avg. [mA]	Time [Hour]	Current Avg. [mA]	Time [Hour]
Balanced 4V Dual DAC	51.30	8.77	66.80	7.49
Balanced 2V Dual DAC	40.00	12.50	51.90	9.63
Unbalanced 2V Single DAC	30.60	16.34	38.00	13.16
Unbalanced 1V Single DAC	25.00	20.00	30.40	16.45

LDAC 44.1KHz @ 909Kbps

	Standard Mode		Performance Mode	
	Current Avg. [mA]	Time [Hour]	Current Avg. [mA]	Time [Hour]
Balanced 4V Dual DAC	55.00	9.09	70.20	7.12
Balanced 2V Dual DAC	42.70	11.71	55.40	9.03
Unbalanced 2V Single DAC	33.00	15.15	40.50	12.35
Unbalanced 1V Single DAC	27.20	18.38	32.80	15.24

LDAC 96KHz @ 990Kbps

	Standard Mode		Performance Mode	
	Current Avg. [mA]	Time [Hour]	Current Avg. [mA]	Time [Hour]
Balanced 4V Dual DAC	59.20	8.45	74.50	6.71
Balanced 2V Dual DAC	46.90	10.66	59.70	8.38
Unbalanced 2V Single DAC	35.40	14.12	43.10	11.60
Unbalanced 1V Single DAC	29.80	16.78	36.10	13.85

ES9219 DAC/AMP - Amplifier Gain

- **User-selectable amp gain mode**
 - Normal 1V RMS
 - High 2V RMS
 - Both provide the same sound performance.
- **Normal 1V RMS mode**
 - Recommended for the most IEMs
 - Longer battery time and the lower noise floor
- **High 2V RMS mode**
 - 6dB higher maximum output level
 - Recommended for headphones
- **Auto Volume Correction**
 - The firmware adjusts the volume and keeps the current output level when switching the gain mode.
 - You will experience no difference in loudness when switching the mode to 2VRMS. But you will have the max volume extended by +6dB.
- The gain mode switching requires a couple of seconds of audio stabilizing time. You may experience some audio artifacts during the transition period.



ES9219 - DAC Operating Profile

- Qudelix's proprietary software drives ES9219 DACs in two ways to trade off the battery time and sound quality.
- **Standard Profile (ECO mode)**
 - Standard DAC Operating Clock
 - Standard Output Bias Current
 - Best Efficiency
 - The best trade-off for battery time and sound quality
 - Suitable for mobile and outdoor use cases
- **Performance Profile (SPORT mode)**
 - Highest DAC Operating Clock
 - High Output Bias Current
 - Best Performance
 - Best Sound Quality with lesser battery time
- Powering to the device with external USB power overrides the current profile and switches it to PERFORMANCE automatically.



UNBALANCED (Single-Ended) 3.5mm

- Works with Single ES9219
 - Max. 2V RMS output
 - 80mWatt per channel
- 3-Wire Interface
 - 2 ch DAC/AMP for Stereo Audio
 - 1-pin Ground
- Common Ground
 - Ground Pin goes to both Speaker-L and Speaker-R
 - Ground ripple(noise) affects both L & R channel
- Both AMP_NOISE and GROUND_NOISE affect the Sound Quality
 - $VL = L_AUDIO + AMP_NOISE + GROUND_NOISE$
 - $VR = R_AUDIO + AMP_NOISE + GROUND_NOISE$

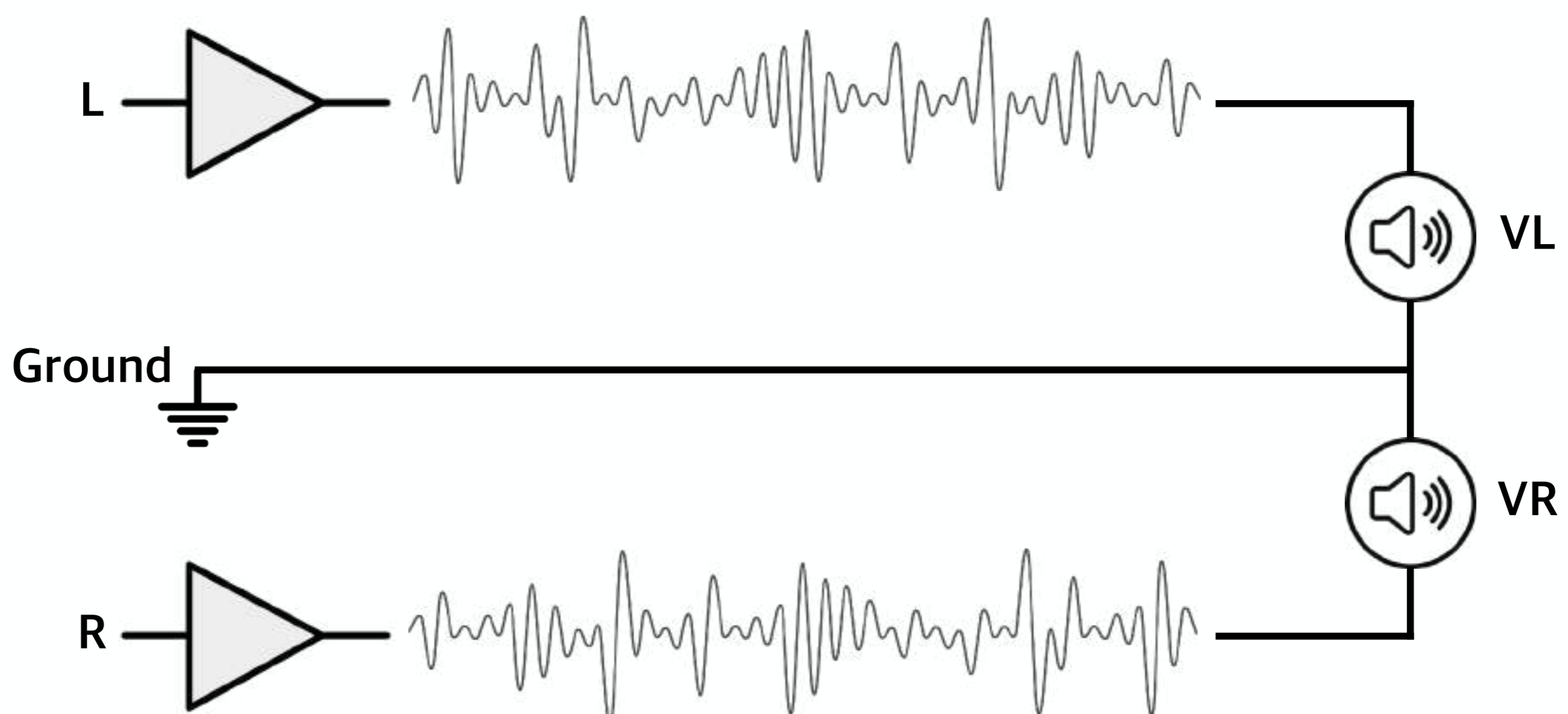

BALANCED (Full-Differential) 2.5mm

- Works with Dual ES9219
 - Max. 4V RMS output
 - 240mWatt per channel
- 4-Wire Interface
 - 4ch DAC/AMP fully wired to the stereo speaker terminals
 - Original Signal (L+/R+) and Inverted(Negative) Signal (L-/R-)
- Free from Ground Noise
- Common Mode Noise Reduction
 - Common AMP_NOISE is canceled out easily
 - $VL = (LP_AUDIO + AMP_NOISE) - (LN_AUDIO + AMP_NOISE) = LP_AUDIO - LN_AUDIO = 2L_AUDIO$
 - $VR = (RP_AUDIO + AMP_NOISE) - (RN_AUDIO + AMP_NOISE) = RP_AUDIO - RN_AUDIO = 2R_AUDIO$
- Relatively better Sound Quality
 - Better Linearity
 - Better Channel Separation
 - 2x more power and driving capability

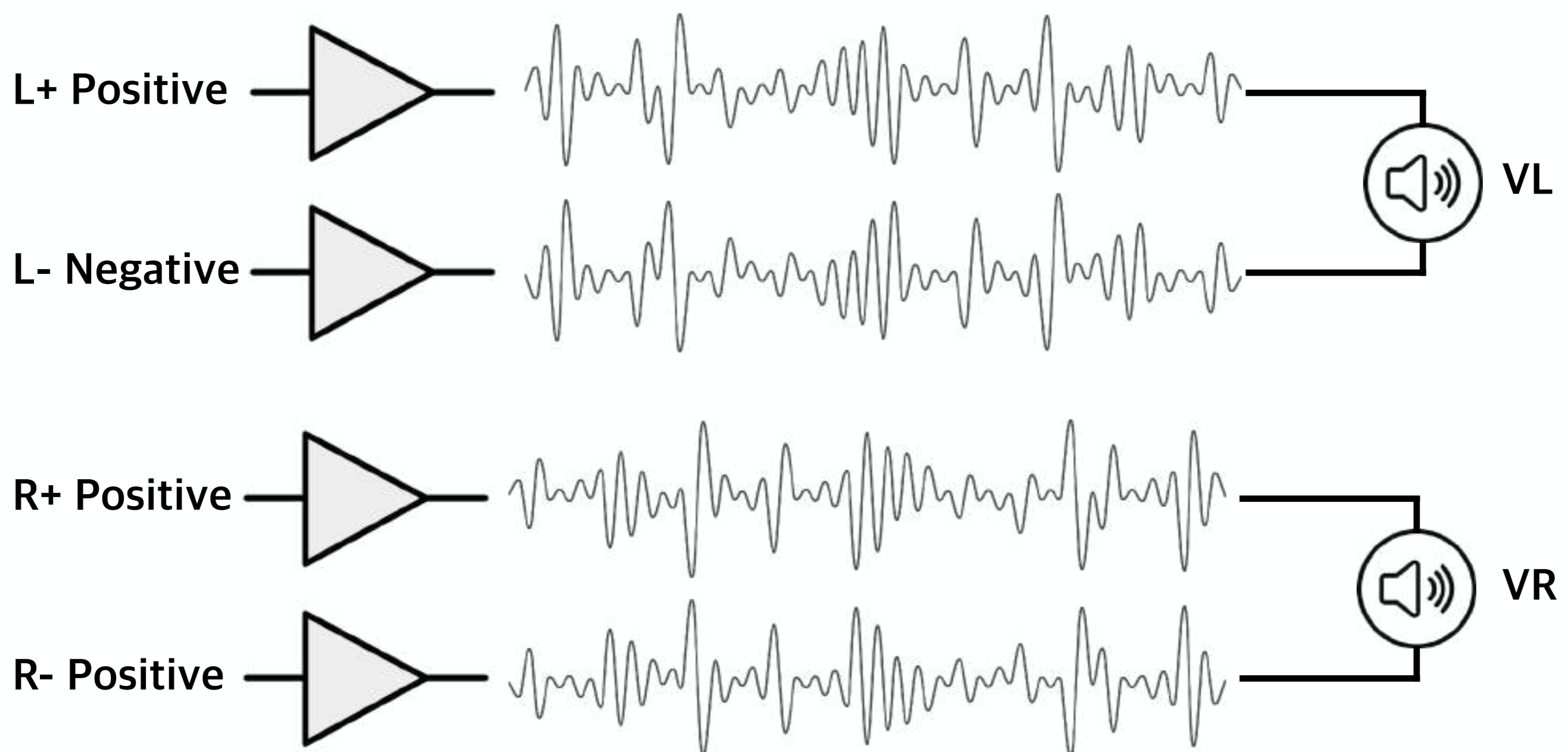
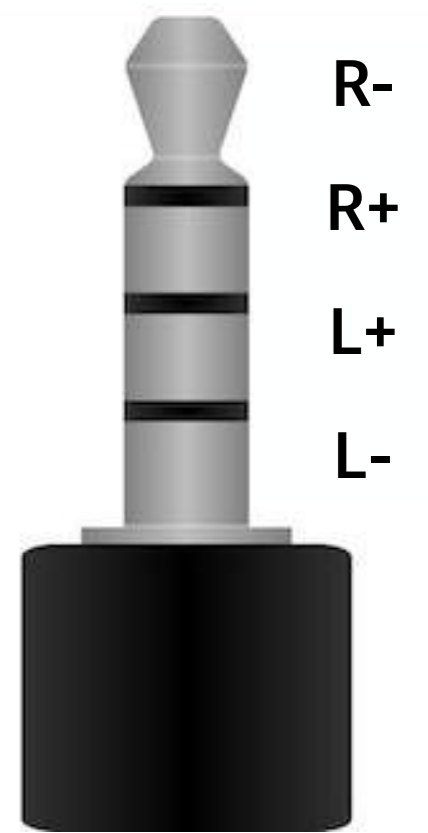

*With any given hardware device supporting UNABL and BAL, BAL always performs relatively better than UNBAL, and we highly recommend using BAL always if available.

ES9219 Built-In PGA (Programmable Gain Amp)

- Analog Volume Control
 - Integrated PGA(Programmable Gain Amp)
 - 0dB ~ -24dB Range
 - 1dB Step
 - Provides the best sound quality at any volume level
 - Noise level gets lowered as the volume level gets reduced.
- 5K manages the output level with the ES9219 built-in PGA, providing optimal sound quality at any given volume level.

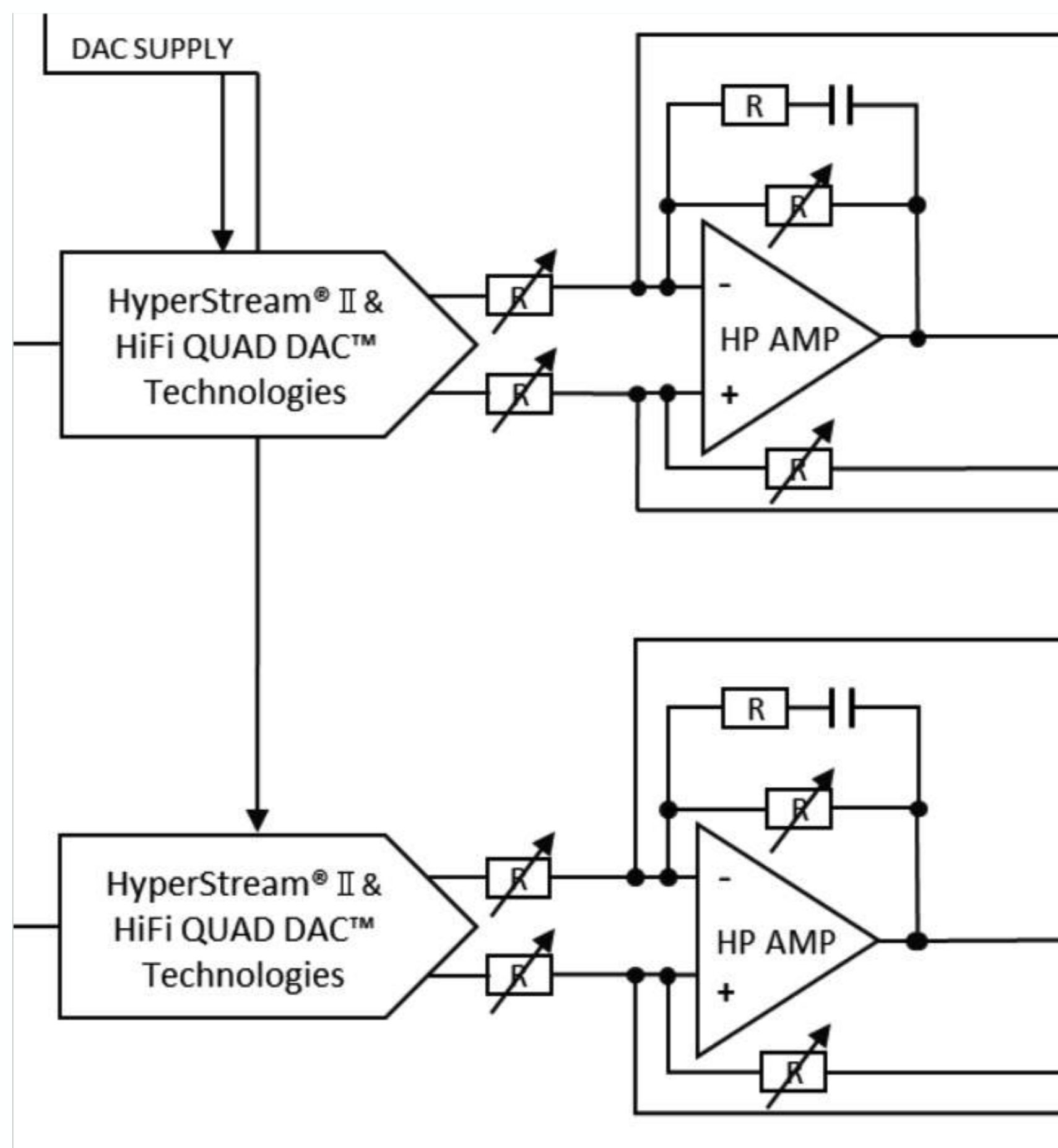

ES9218P DAC & HPAMP

with PGA(Programmable Gain Amplifier)

Volume

- 5K offers 2-way associative absolute volume control for optimal sound quality and always keeps and guarantees the full-scaled audio stream over Bluetooth or USB.
- Use whatever comfortable way you are.
 - Use the smartphone volume for coarse adjustment.
 - Use the 5K volume for fine adjustment.
 - They both provide the same sound quality.

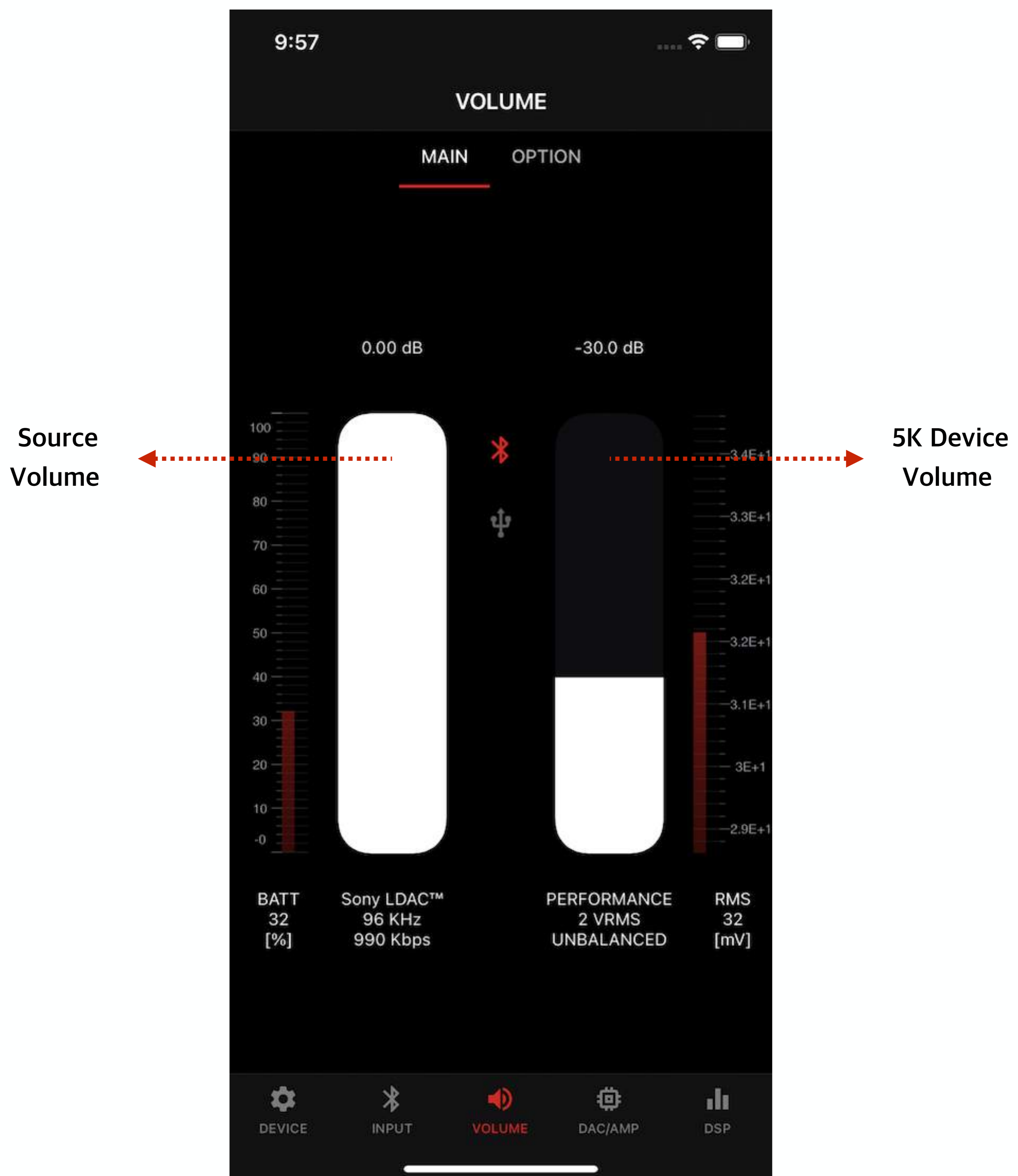

2-way Associative Absolute Volume

- Qudelix's proprietary 2-way associative absolute control provides optimal sound quality at any source or device volume level. With this scheme, the source device always delivers the audio stream at the maximum precision as the original.
- You can control volume in whatever comfortable way, either smartphone buttons or Qudelix-5K buttons without any sound quality loss. It always keeps and guarantees the best sound quality over Bluetooth or USB.
- **Smartphone, PC/Laptop volume control**
 - Remotely adjusts 5K built in Volume Controller
 - 2dB step Coarse Control
- **5K Device Volume Control**
 - 0.5dB step Fine Control
- **Optimal sound quality for any volume settings**
 - Any smartphone's or 5K's volume setting provides the best sound quality while keeping the best audio precision.

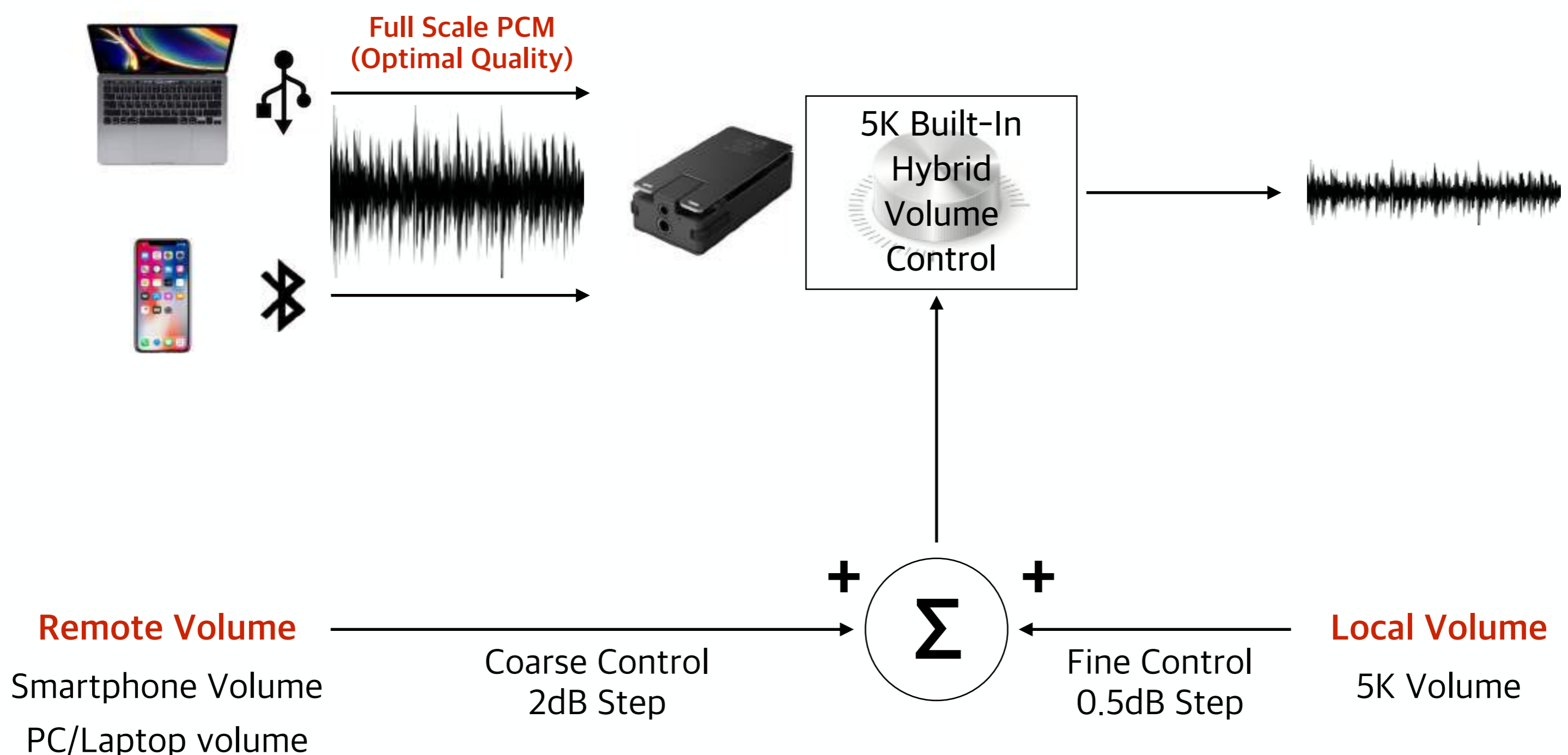

2-way Associative Absolute Volume

- Android provides an option for the Bluetooth absolute volume, named 'Disable absolute volume.' As in the screenshot below, it should be off.

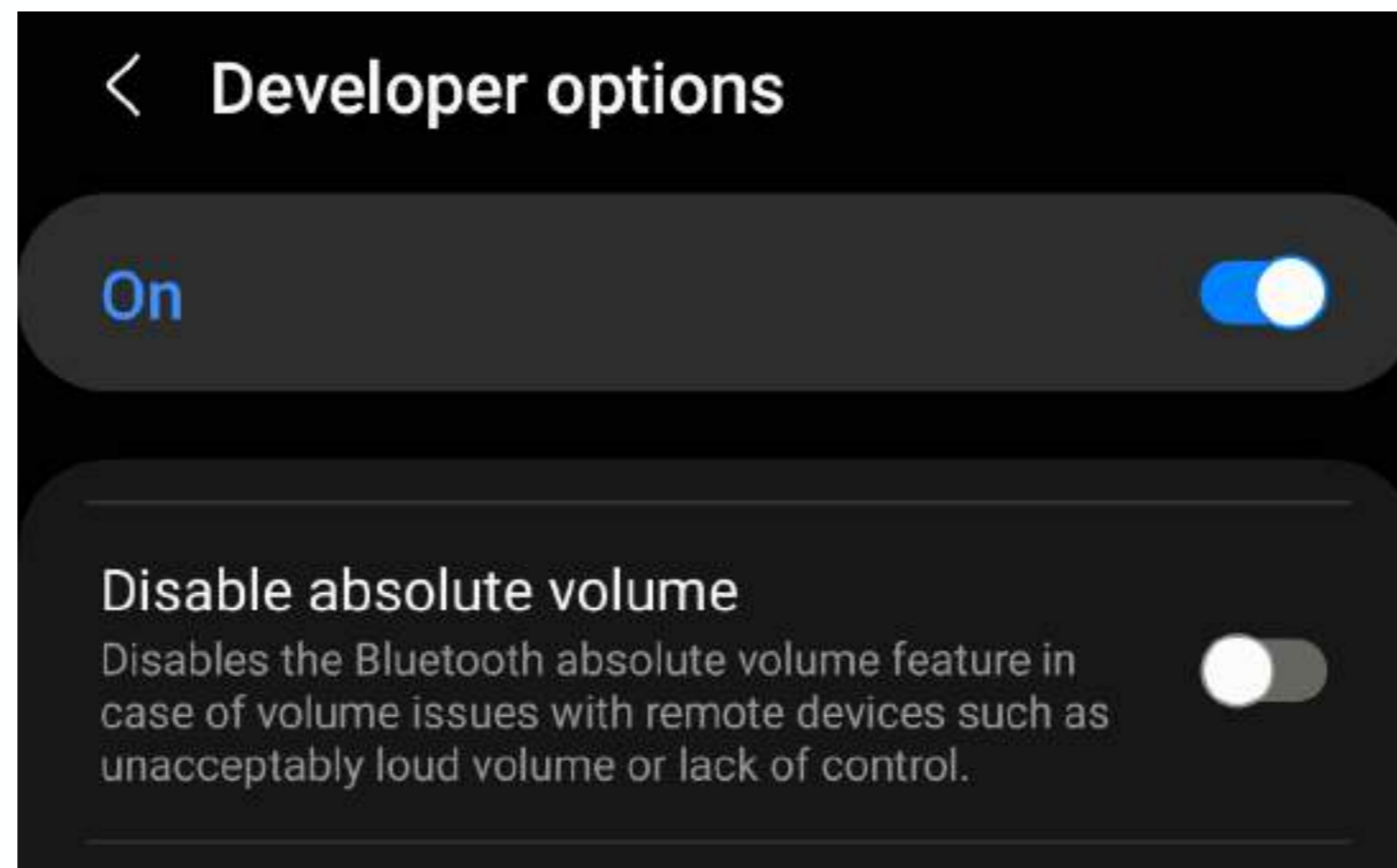

- How to check if the ABS volume is working
 - When you adjust the source volume (i.e., smartphone or pc volume), the source device sends the volume command to the 5K. And the 5K will blink the Blue LED once it receives the volume command.
 - If the ABS volume is off, the source scales down the PCM audio and sends no command to the 5K. Thus the 5K Blue LED will not blink.
 - To confirm the ABS volume is working, check if the 5K Blue LED blinks upon the source device volume adjustment.
- NOTE: Android USB Audio doesn't support Absolute Volume Control.

Source	ABS Volume Support
Windows/MacOS/Linux USB	O
iOS USB	O
Android USB	X
Bluetooth	O

Volume & Input RMS

- The Level RMS will display the instantaneous average of the incoming audio for every 1 second.
 - The level will change continuously as a music track goes on.
 - Or, if you play a static test tone or noise with a constant level, they will keep displaying a certain level.
- Monitoring the incoming RMS level at the 5K is one way to check if Absolute Volume Control is working. Without the ABS volume control, the RMS level will decrease as the source device volume decreases.

The screenshot shows the 'INPUT' settings screen on an Android device. At the top, the time is 1:12 and there are icons for signal strength, Wi-Fi, and battery. The screen is titled 'INPUT' and has a navigation bar at the bottom with icons for DEVICE, INPUT (highlighted in red), VOLUME, DAC/AMP, and DSP. The main content is a list of audio input parameters:

STATE	CODEC	USB	MIC	PRIORITY
ACTIVE STATE				
STATE	BLUETOOTH (A2DP #1)			
SOURCE	64:7b:ce:2e:34:e1			
CODEC	Sony LDAC™			
SAMPLE RATE	96 KHz			
BITS PER SAMPLE	24 BIT			
BIT RATE	990 Kbps			
LEVEL RMS [dB]				
LEFT	-0.00			
RIGHT	-0.00			

Below the table, there is explanatory text:

In general, LDAC 606/660kbps or higher provides excellent sound quality comparable to the wired interface. If you don't get sufficient sound quality, please set a higher LDAC bit rate in the Android Developer Options menu.

Some specific Android smartphones may not be able to provide reliable 990kbps streaming. Turning off the smartphone display, or using 5GHz WiFi might help the LDAC streamed a little better.

The 660kbps is the best trade-off for reliable streaming and sound quality. In most cases, you would get good enough sound quality with LDAC 660kbps.

Bluetooth Codec - LDAC

- **SONY LDAC**

- Available with Android 8.0 or higher.
- LDAC 606/660kbps or higher generally provides excellent sound quality comparable to the wired interface. If you don't get sufficient sound quality, please set a higher LDAC bit rate in the Android Developer Options menu.
- Some specific Android smartphones may not be able to provide reliable 990kbps streaming. Turning off the smartphone display or using 5GHz WiFi might help the LDAC stream a bit better.
- The LDAC 660kbps is the best trade-off for reliable streaming and sound quality. In most cases, you would get good enough sound quality with LDAC 660kbps.

- **Enable SONY DAC**

- Bluetooth Menu → Paired Devices → Qudelix-5K → device option → LDAC

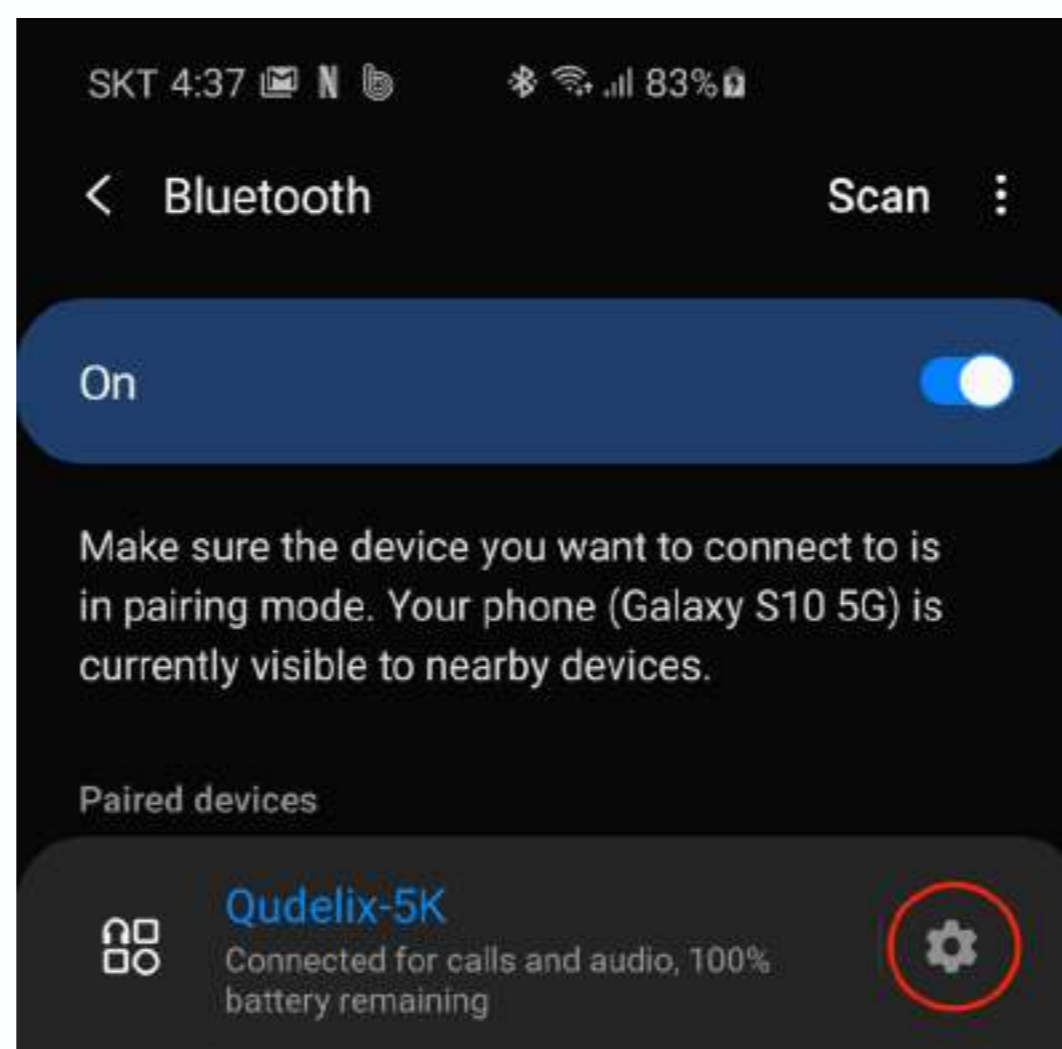

- **Setting LDAC Bitrate & Sample Rate**

- Enable Android Developer Option
 - <https://developer.android.com/studio/debug/dev-options?hl=en>
 - Please refer to the link above and enable the developer options menu.
- System Setting → Developer Option → LDAC Quality

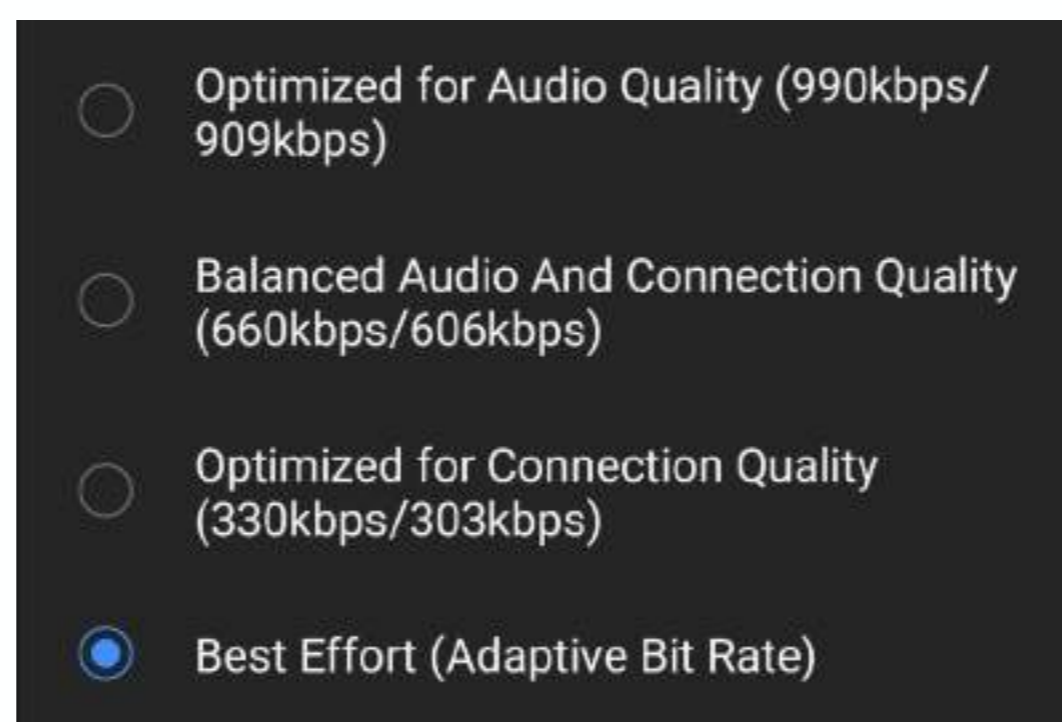

Power & Battery Management

- 5K has three power management modes, as shown in the block diagrams below.
 - Battery Powered
 - USB Powered & Charging ON
 - USB Powered & Charging Off

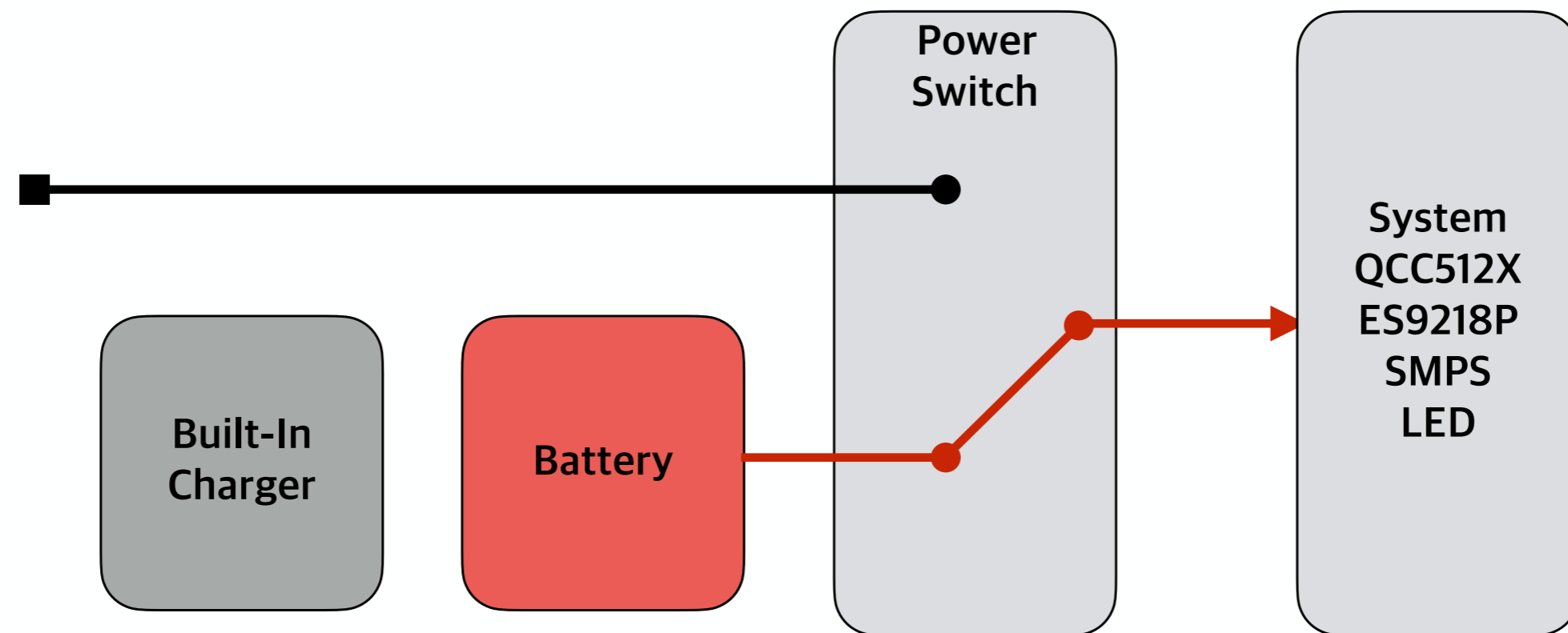

a) Battery Powered

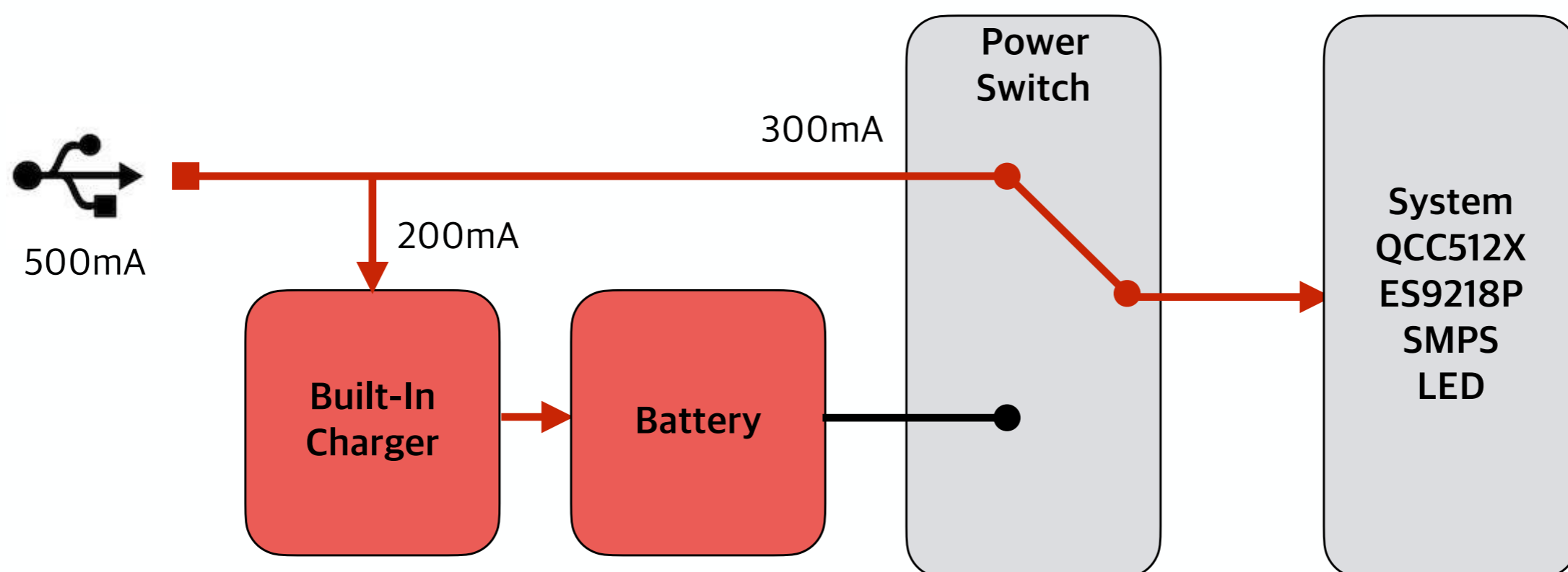

b) USB Powered & Charging

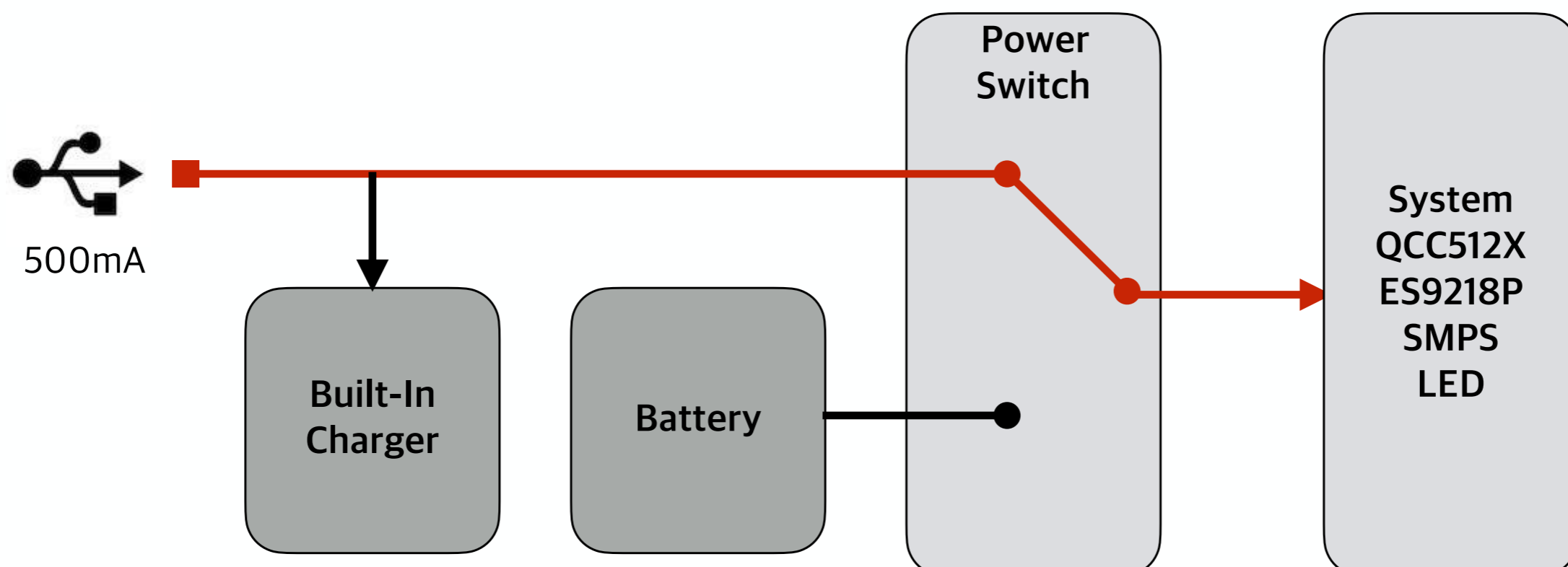

c) USB Powered & Charging Completed or Off

Power & Battery Management

- **Battery Powered Mode**
 - 5K works with the built-in battery.
 - It's the most typical use case for wireless streaming over Bluetooth.
- **USB Powered with charging on**
 - You can use 5K while charging the battery without any worries.
 - 5K always sources its operating power from the USB VBUS, if available.
 - For example, when you connect the 5K to a PC USB, smartphone USB, or USB charger, 5K automatically switches the power source from the battery to the USB through the built-in power switch.
 - The external USB VBUS provides 5K operating power and charges the built-in battery simultaneously.
 - It keeps the battery life longer and guarantees static battery charging time.
 - When the battery gets fully charged, 5K automatically turns off the built-in charger, cutting the current flow to the battery.

 - *Some devices always draw the operating power from the battery; in that case, the device charges the battery while simultaneously discharging the battery, eventually killing the battery life and causing unexpected heat.
- **USB Powered with charging off**
 - You can manually turn off the 5K built-in charger for mobile USB DAC use case.
 - iOS devices can supply output current to the accessory up to 150mA only.
 - If you connect the 5K to an iPhone over USB, you must turn off the 5K built-in charger. Otherwise, the 5K will draw too much power from the iPhone, and consequently, the iPhone will drop the connection with the accessory.

Connecting 5K to multiple source devices

- **Multi-Functional DAC**
 - 5K is a multi-functional DAC supporting Bluetooth A2DP and USB Audio Class.
 - As in the block diagram below, you can have multiple connections simultaneously with two Bluetooth Audio source devices and one USB Audio source device.
- **5K can keep the connections with multiple source devices, Bluetooth or USB, but it can stream audio from a single source device one by one at a time.**
 - For example, a smartphone and a pc can stream audio to the 5K simultaneously over Bluetooth and USB, respectively. In this case, 5K needs to select one input source based on its priority policy.



Input Source Priority

- **Multiple connections with multiple source devices**
 - 5K can stream audio from one source device at a time, thus, when multiple source devices stream audio to a 5K simultaneously, 5K selects one input.
- **Bluetooth and USB icon buttons**
 - They appear when 5K connects with each source device over the respective link.
 - The icon in Red represents the active audio source currently streaming.
 - The icons are buttons, and pressing an icon would change the input priority.

Bluetooth connection
with a smartphone

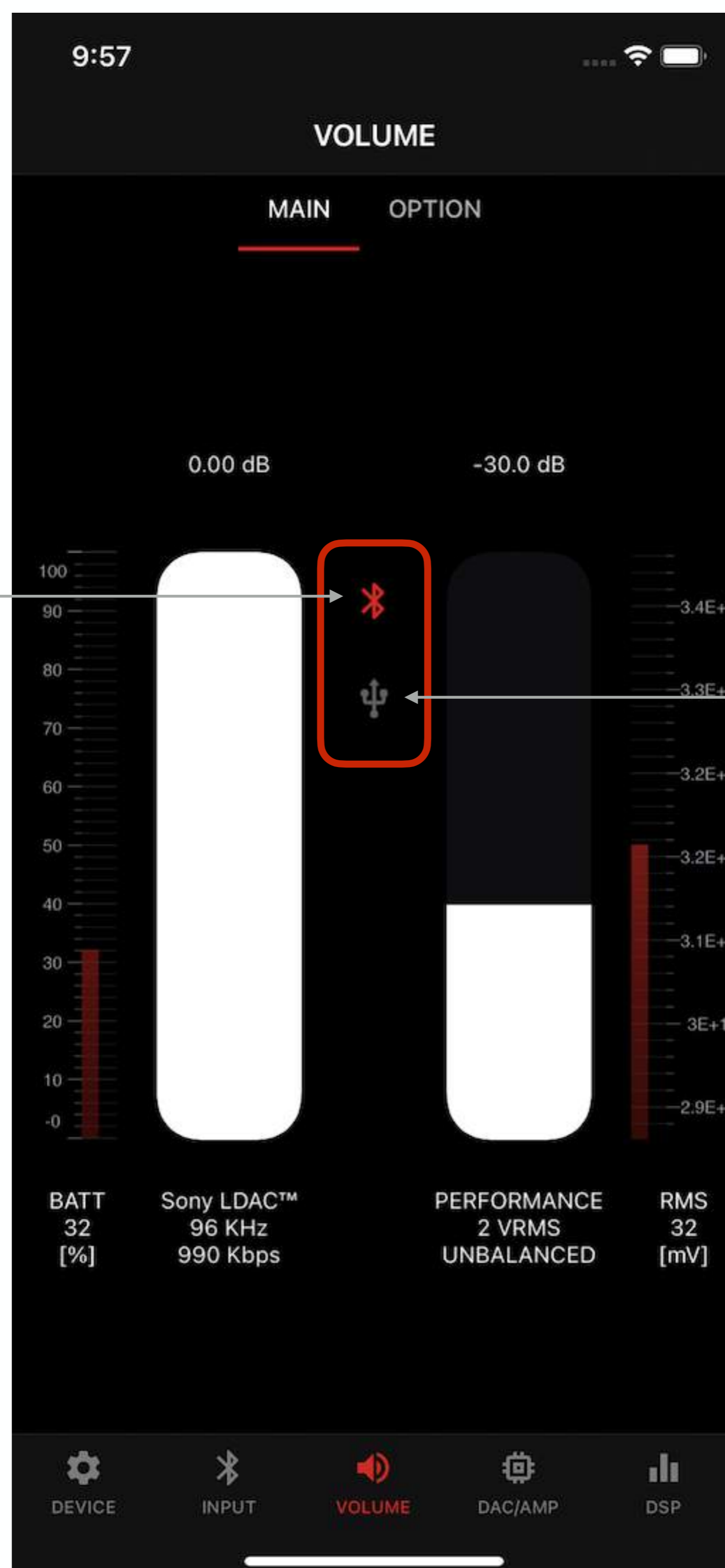

USB connection
with a PC

Multiple connections with a single source device

- **Multiple Audio Output Devices**

- You can connect a 5K to a smartphone with Bluetooth and USB. In this case, the smartphone has two output devices; one is 5K Bluetooth, and the other one is 5K USB.
 - A source device (i.e., a smartphone or a pc) can't output audio to multiple devices. So users SHOULD select the output device to use among the available audio output devices
- *Note that this is nothing to do with the 5K input priority. Instead, you must select the audio output device to use through the iOS/Android control panel.

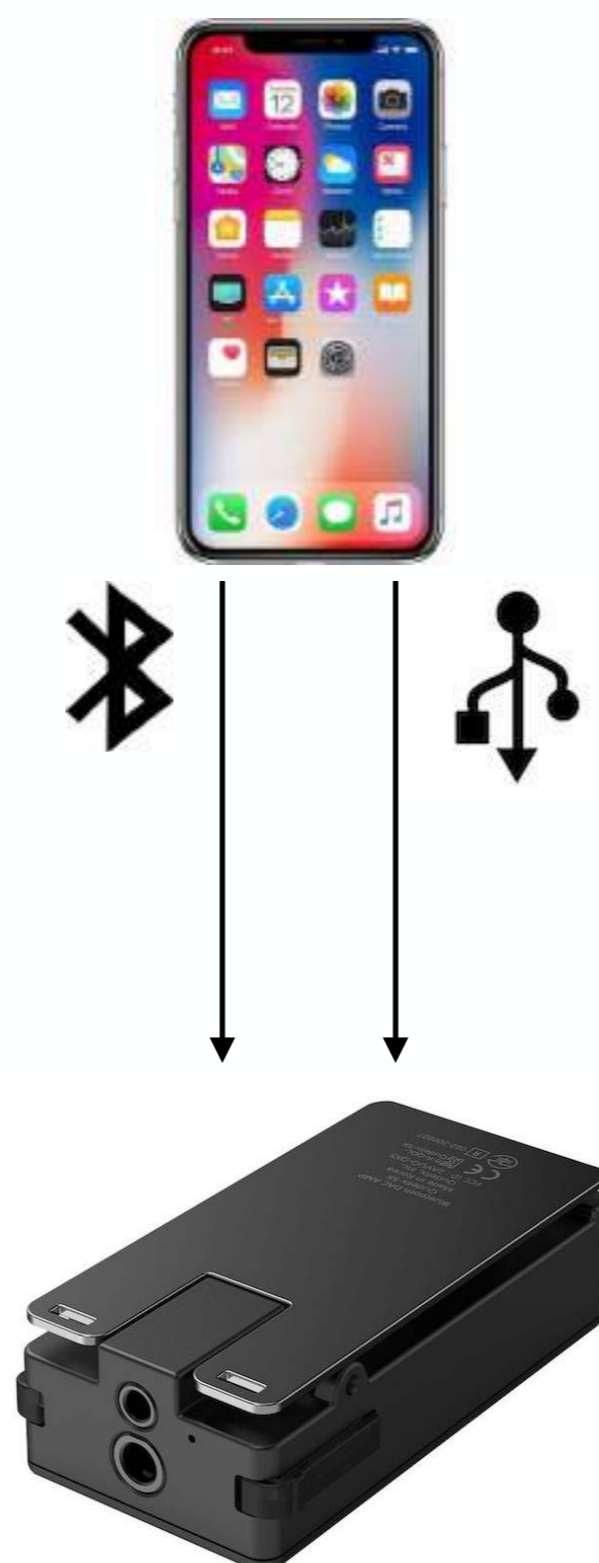

iOS Audio Output Device

- You can simultaneously connect a 5K to an iPhone through Bluetooth and USB (Apple Camera Kit).
- In that case, the iPhone becomes to have multiple audio output devices. And you must select one to use through the iOS control panel.

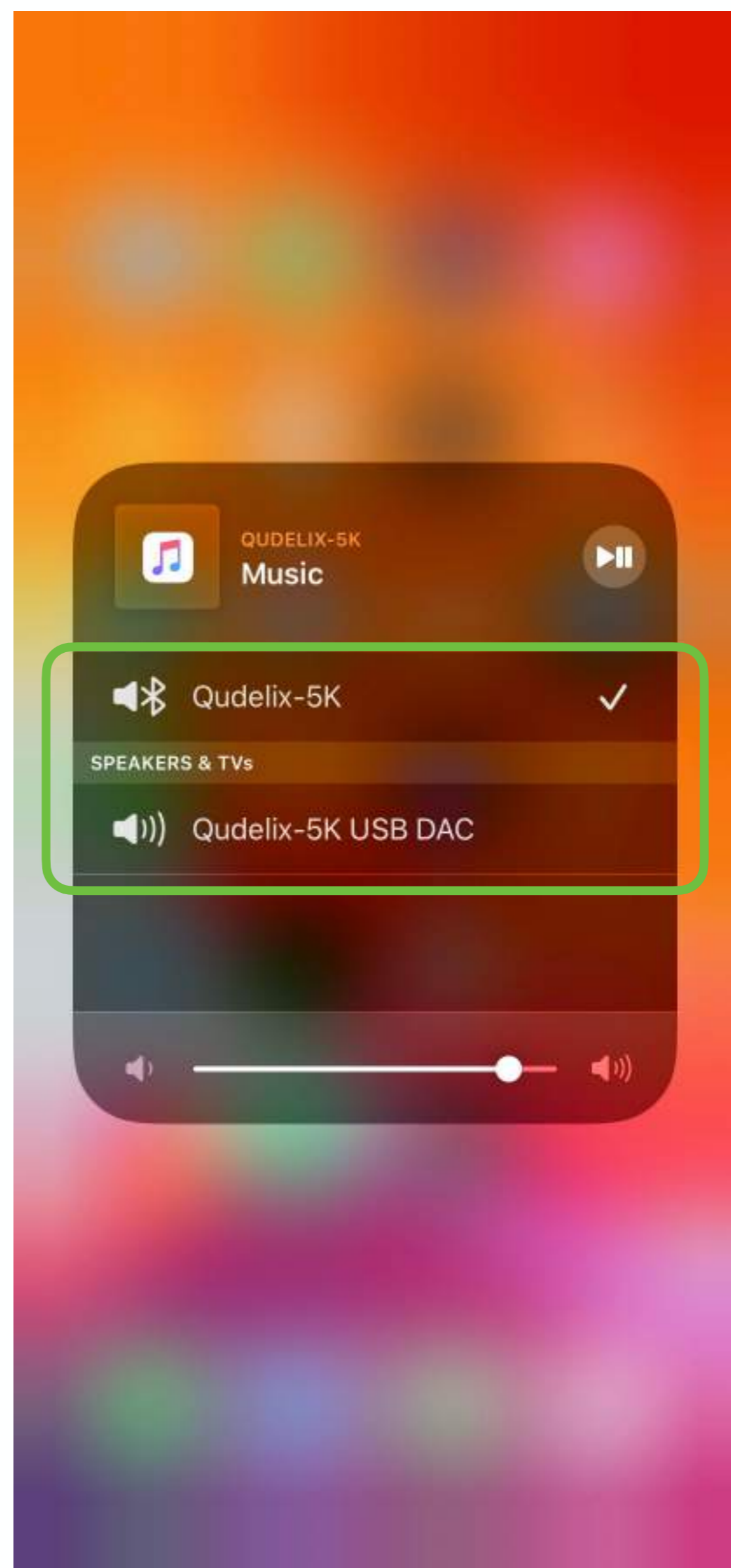
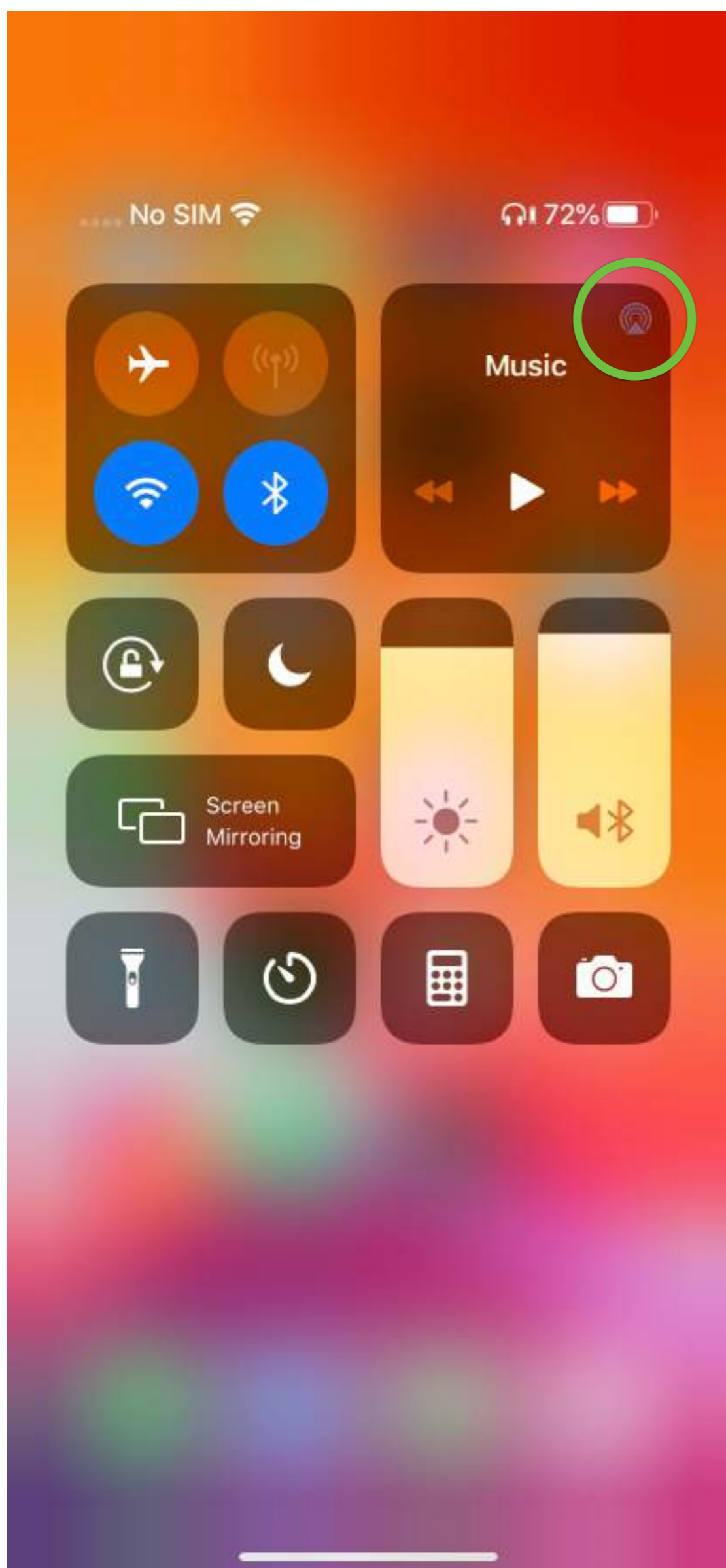

Android Audio Output Device

- In Android, Media → Audio Output, you can select an audio output device to use among multiple devices.
- *The Audio Output Selection system menu may differ across smartphone manufacturers, Android versions, and product models.

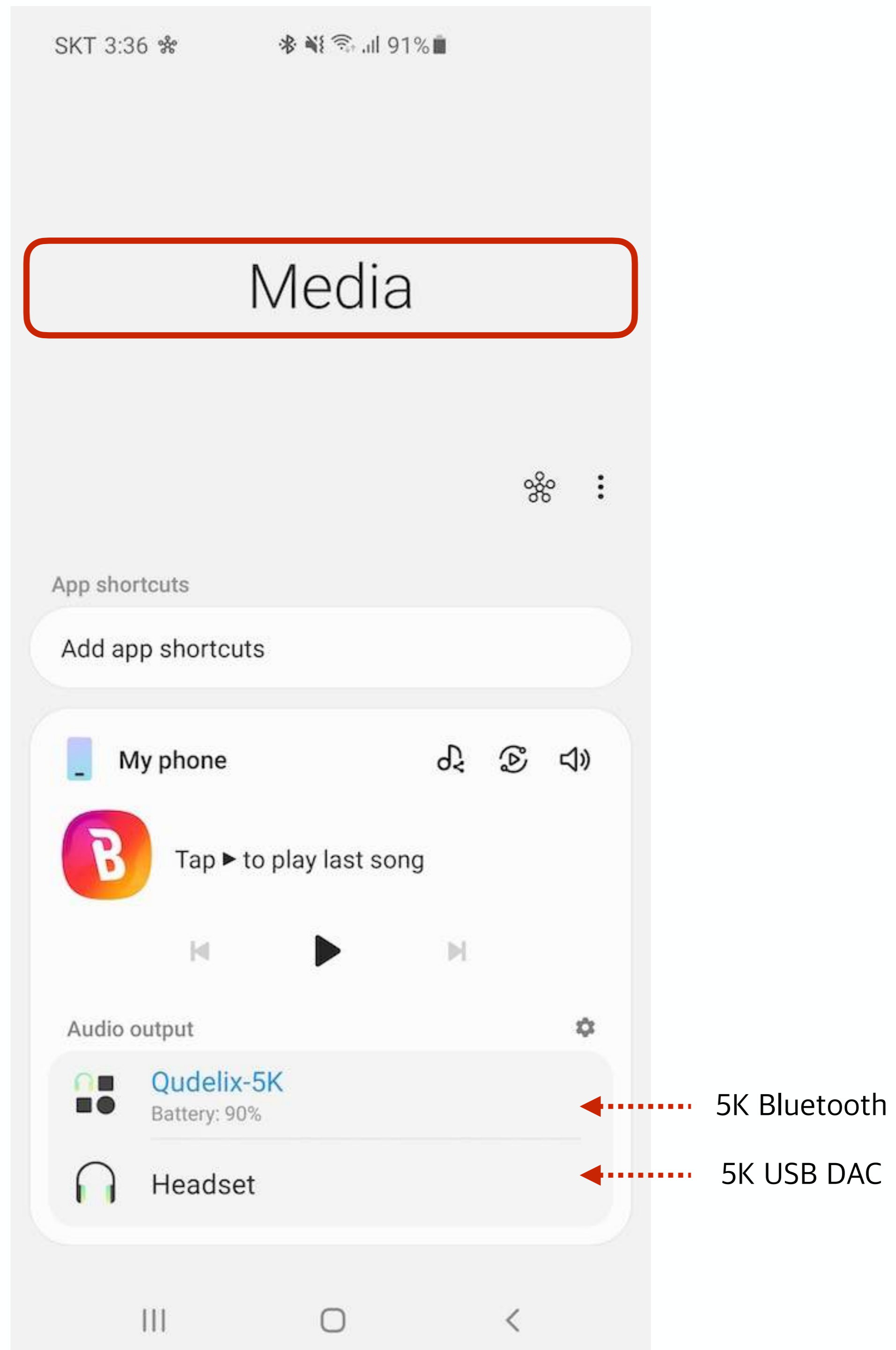

Android Audio Output Galaxy S10

Bluetooth Auto Disconnect for USB DAC

- 'Bluetooth Auto Disconnect for USB DAC' is a new feature with the software v2.0.
 - 5K automatically disconnects any existing Bluetooth Audio Link when connected to a USB Host. And if the USB is disconnected, 5K reconnects the Bluetooth Audio Link.
 - It only disconnects the Audio Link so that you can keep the Qudelix iOS/Android App and the voice call over Bluetooth.
- For example,
 - When you plug a 5K into a smartphone over USB, the 5K automatically disconnects the Bluetooth Audio link.
 - Then, you unplug the 5K from the smartphone, and the 5K automatically reconnects the Bluetooth Audio link.
 - This way, the smartphone will have only one audio output device at a time, the 5K Bluetooth or the 5K USB. It can save you from the tedious work of selecting an audio output device repeatedly.

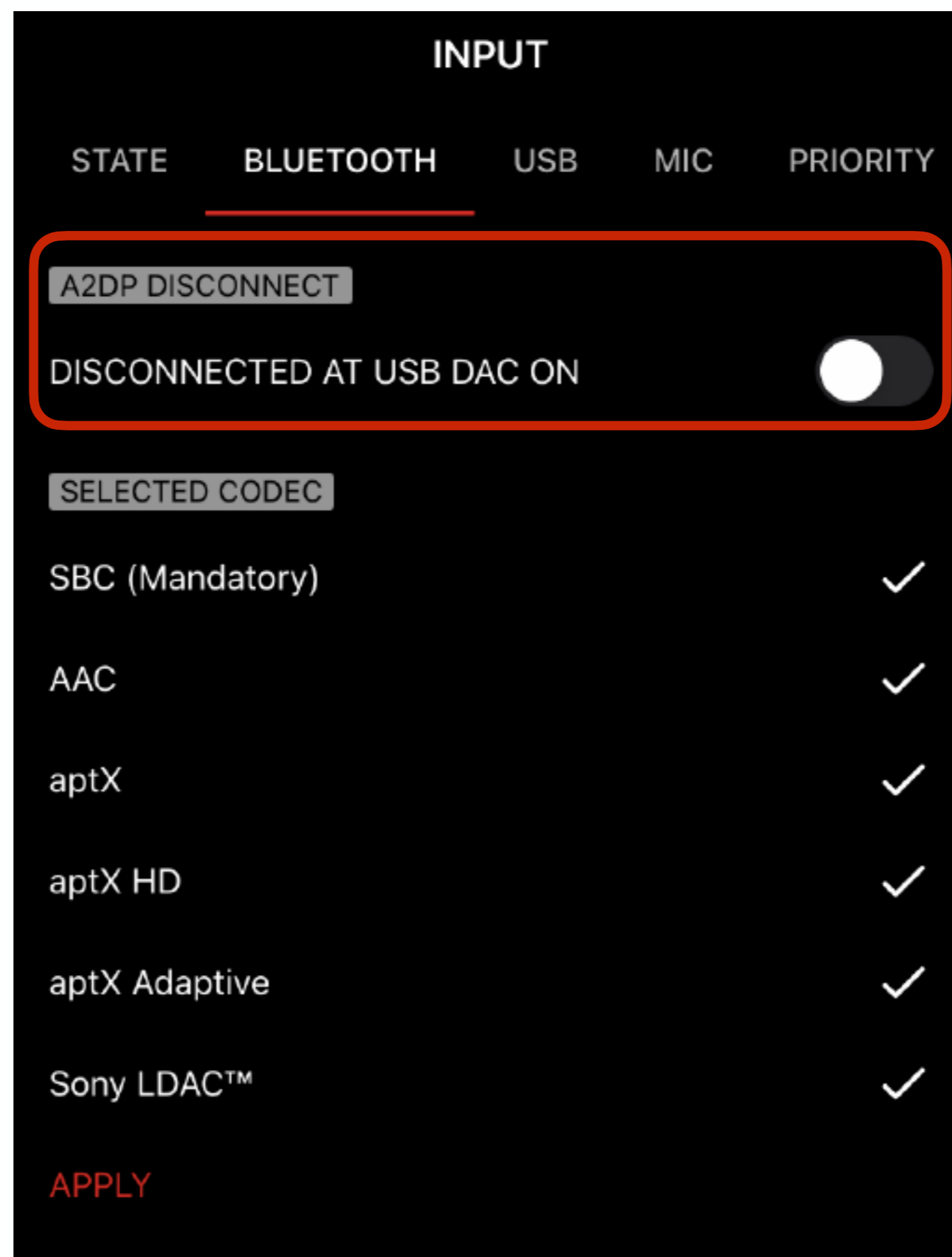

Equalizer

- The embedded pro-grade equalizer is a vital benefit of 5K DAC/AMP over other similar products. It processes every incoming audio from everywhere: Youtube, Apple Music, Spotify, iOS, Android, PC, Bluetooth(all Codecs), and USB.
- 5K DAC/AMP supports parametric EQ and graphical EQ. The embedded DSP cores perform double-precision 64-bit EQ processing, providing the most accurate and precise frequency response even at low-frequency range.
- 5K manages and stores the EQ presets in its internal flash memory. And 5K automatically reloads the settings at boot-up and resumes the same EQ setting as configured before. So, once you configure the EQ using the app, you no longer need to launch the app to see if the EQ runs or not.
- EQ modes
 - 20-Band Equalizer
 - 10-Band L/R Independent Equalizer

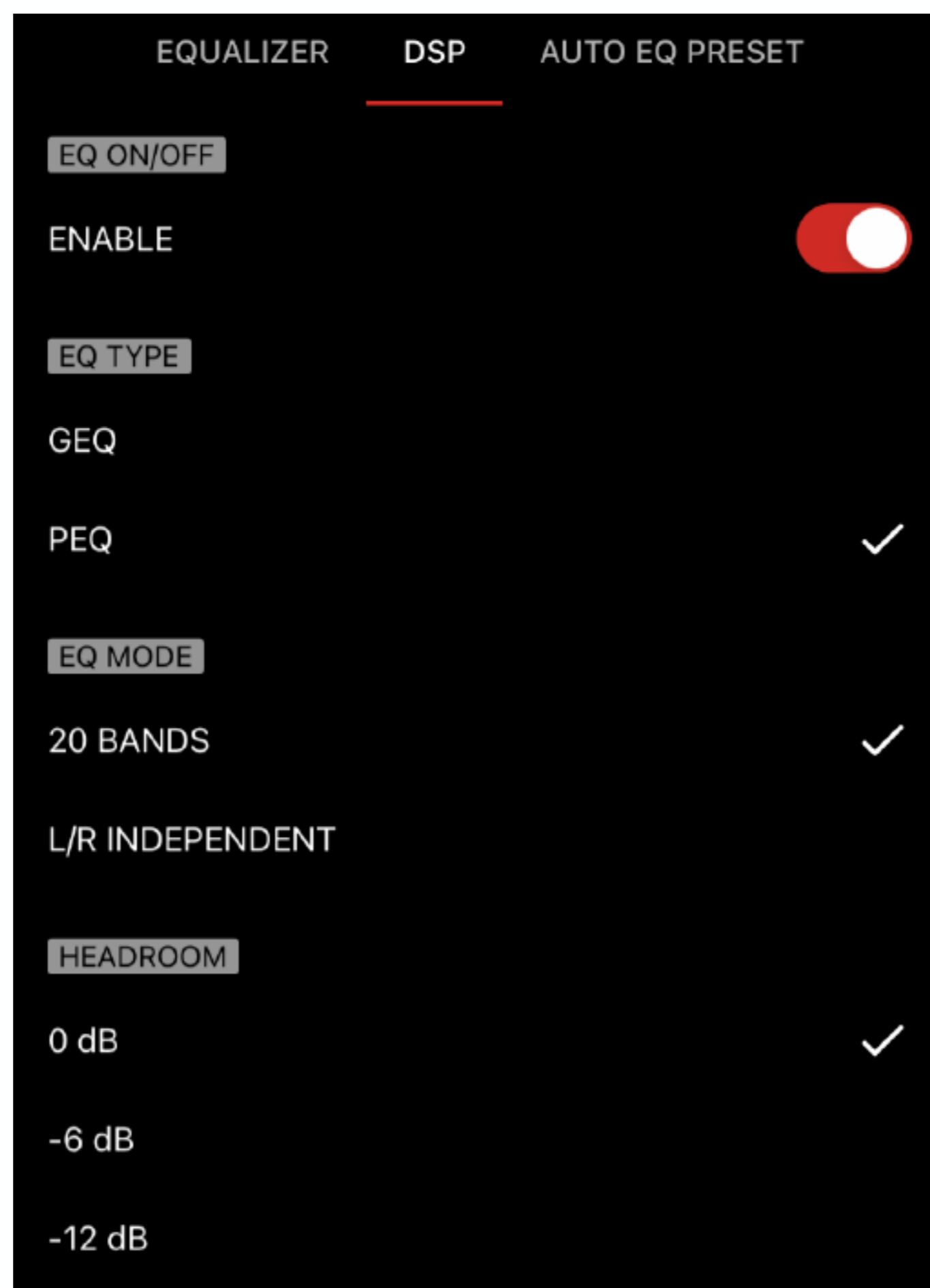

Filter Setting Window

- Tapping the EQ Graph pane will toggle the EQ control panel.
 - Filter setting window
 - Preset list window

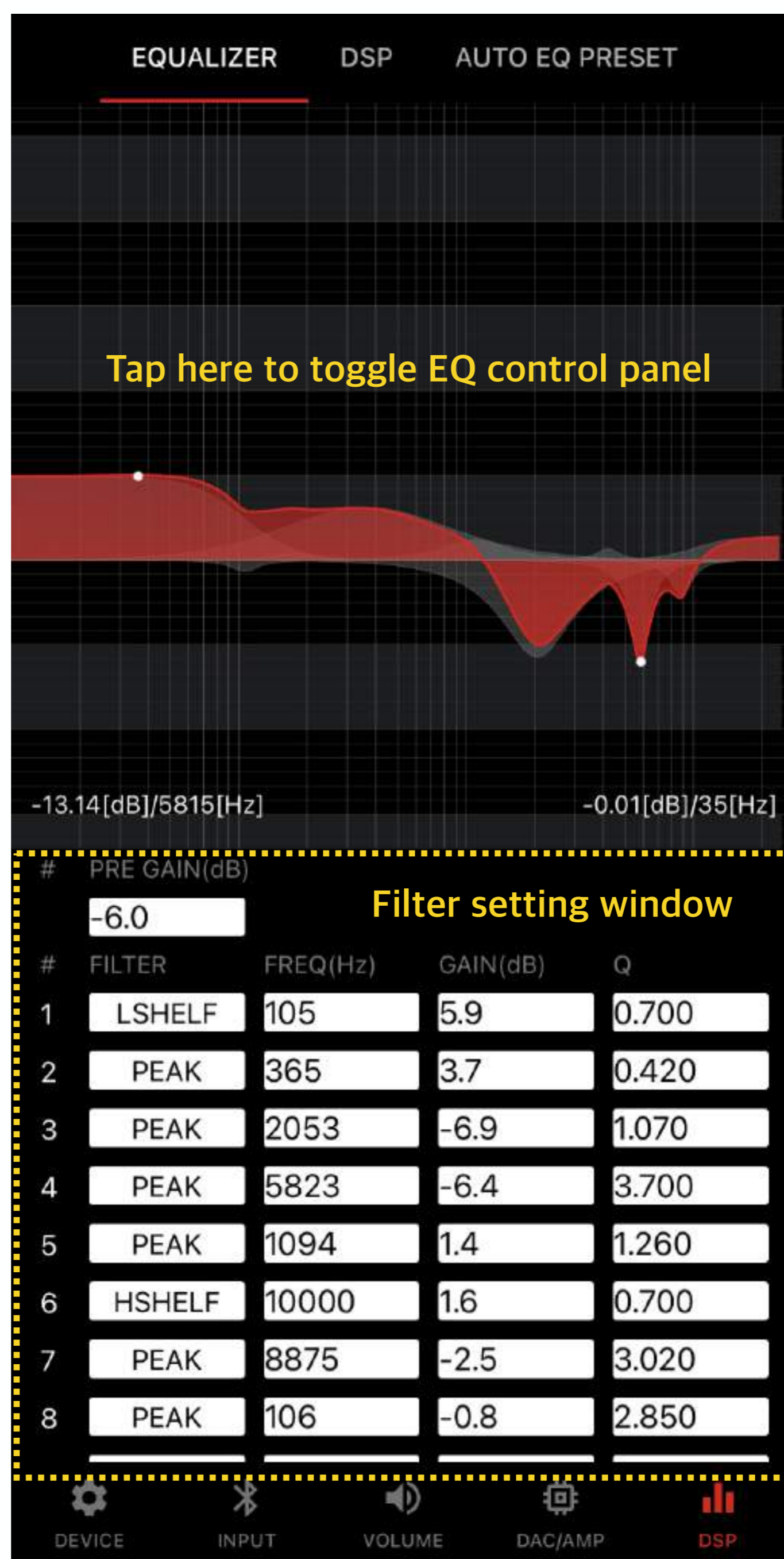

Preset List Window

- Up to 20 Custom User Presets
- 5K manages and stores the EQ presets in its internal flash memory.
- **Long Press(iOS/Android) or Double-click(Chrome) custom#1~#20 will show you the popup window saving the preset.**

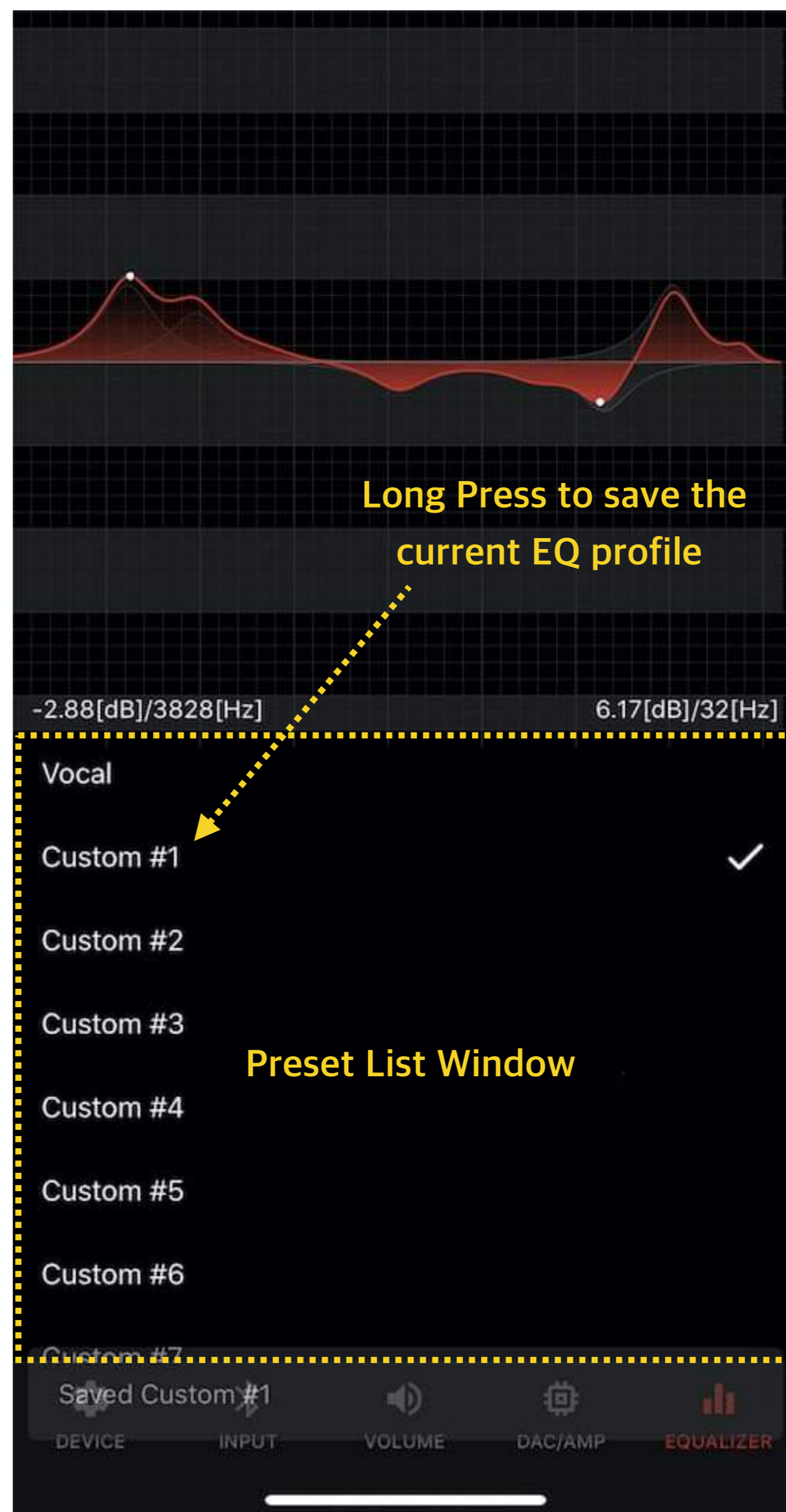

L/R Independent EQ

- Tap the Right or Left Button to toggle the channel.
- The red graph is for the left channel, and the green is for the right.

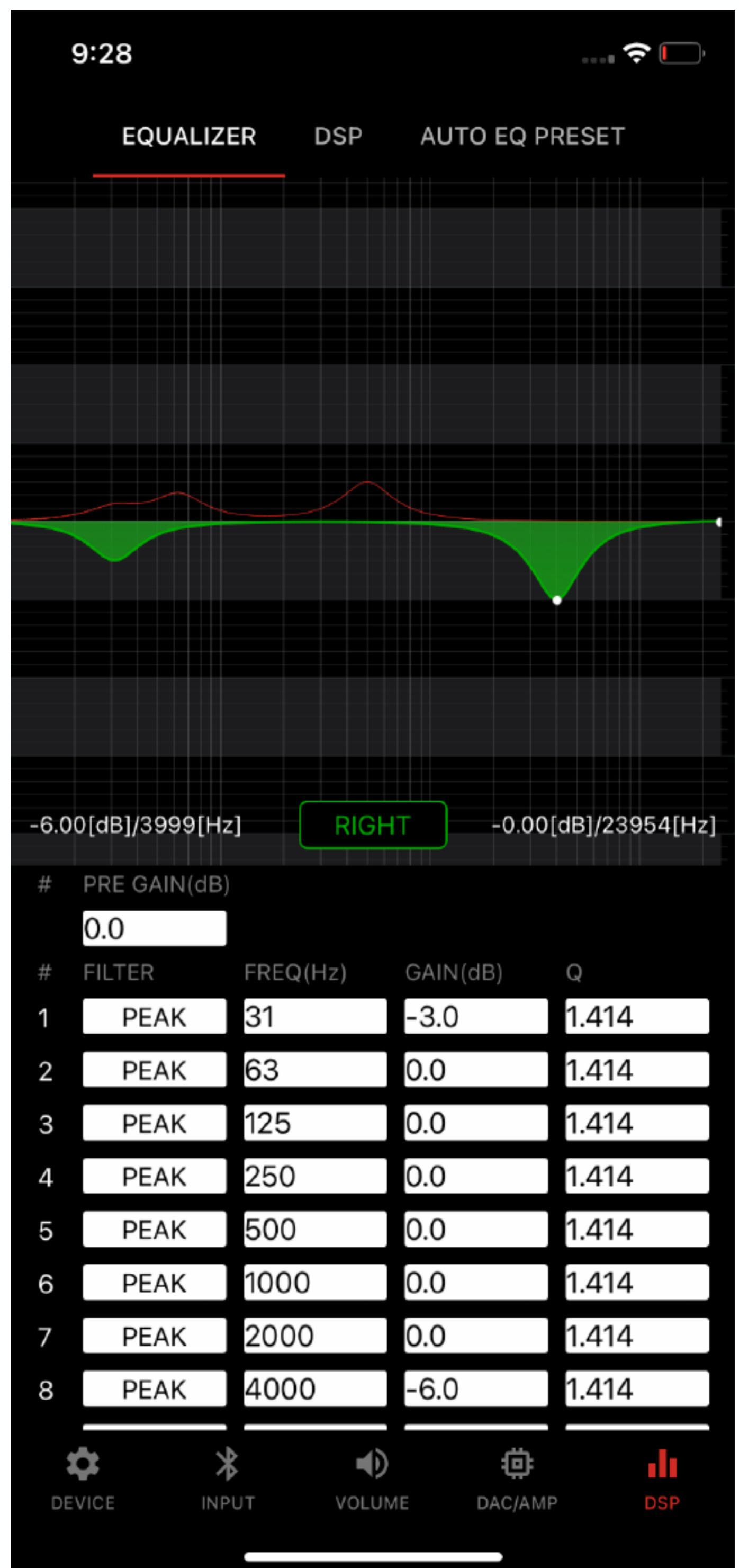
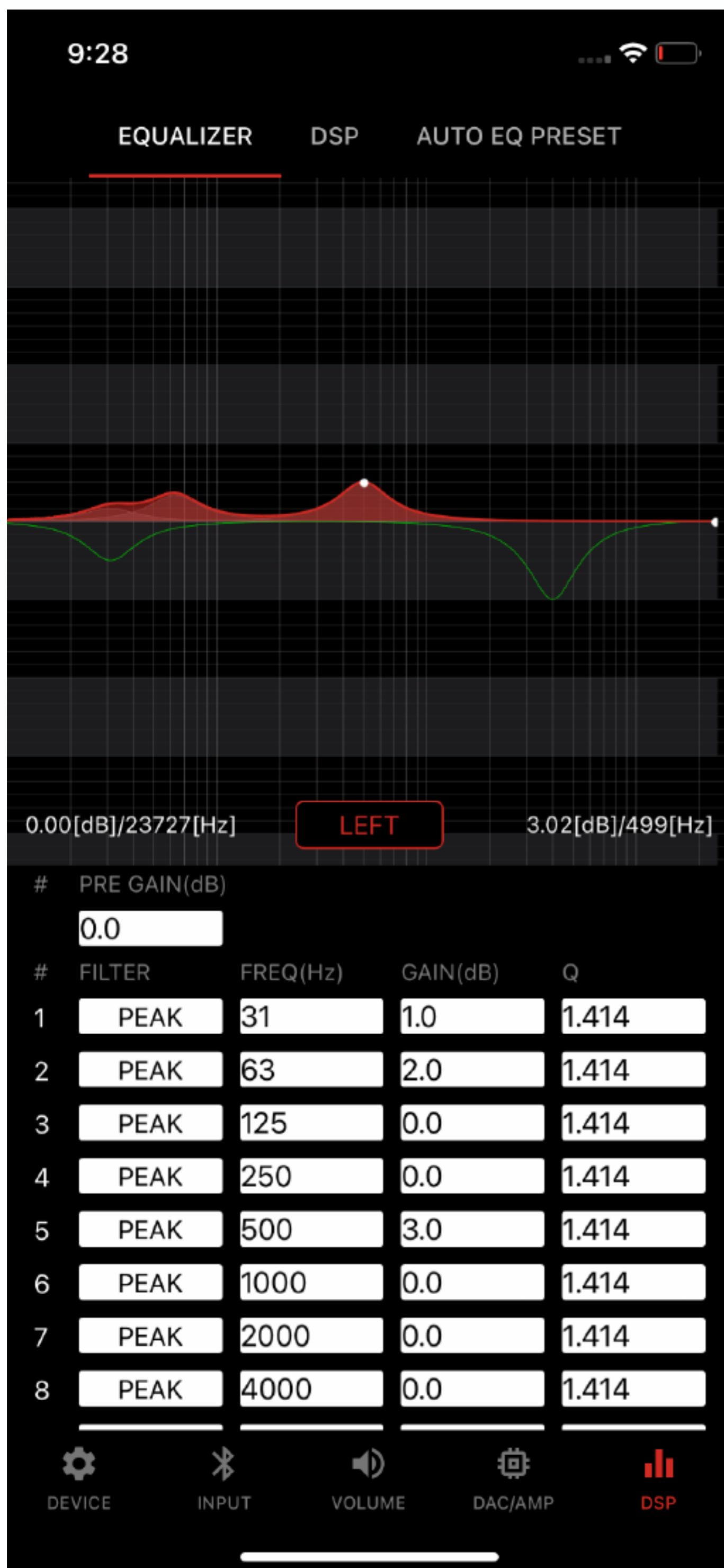

EQ Headroom & Pre Gain

- When an EQ filter gain higher than 0dB, the filter boosts up the input audio, and the audio may get clipped/saturated, resulting in unwanted clipping noise.
- So, we must scale down the input audio before EQ filters, making the frequency peak of an EQ preset no higher than 0dB.
- The Preamp Gain and Headroom are the scale factors applied to the input before EQ filtering.
 - **Scale factor [dB] = Preamp Gain [dB] + Headroom [dB]**
- The EQ headroom is a global factor applied to all EQ presets. And the EQ frequency plot, min/max display, does not reflect the headroom. In other words, the headroom would change the audio output level audibly but not the frequency plot visually.
- Meanwhile, the Preamp Gain works for each EQ preset. And it visually changes the EQ frequency plot and audibly changes the audio output level.

Saving EQ preset

- Long Press(iOS/Android) or Double-click(Chrome) custom#1~#20 will show you the popup window for saving the preset.
- When you save an EQ preset, you can save the impedance and sensitivity profile along with the EQ preset.
- Technically, EQ and Impedance/Sensitivity have nothing to do with each other. However, since most users manage their EQ preset per IEM/Headphone basis, we added the impedance/sensitivity fields in each EQ preset.
- We highly recommend setting Impedance/Sensitivity, but you can leave them as zeros.

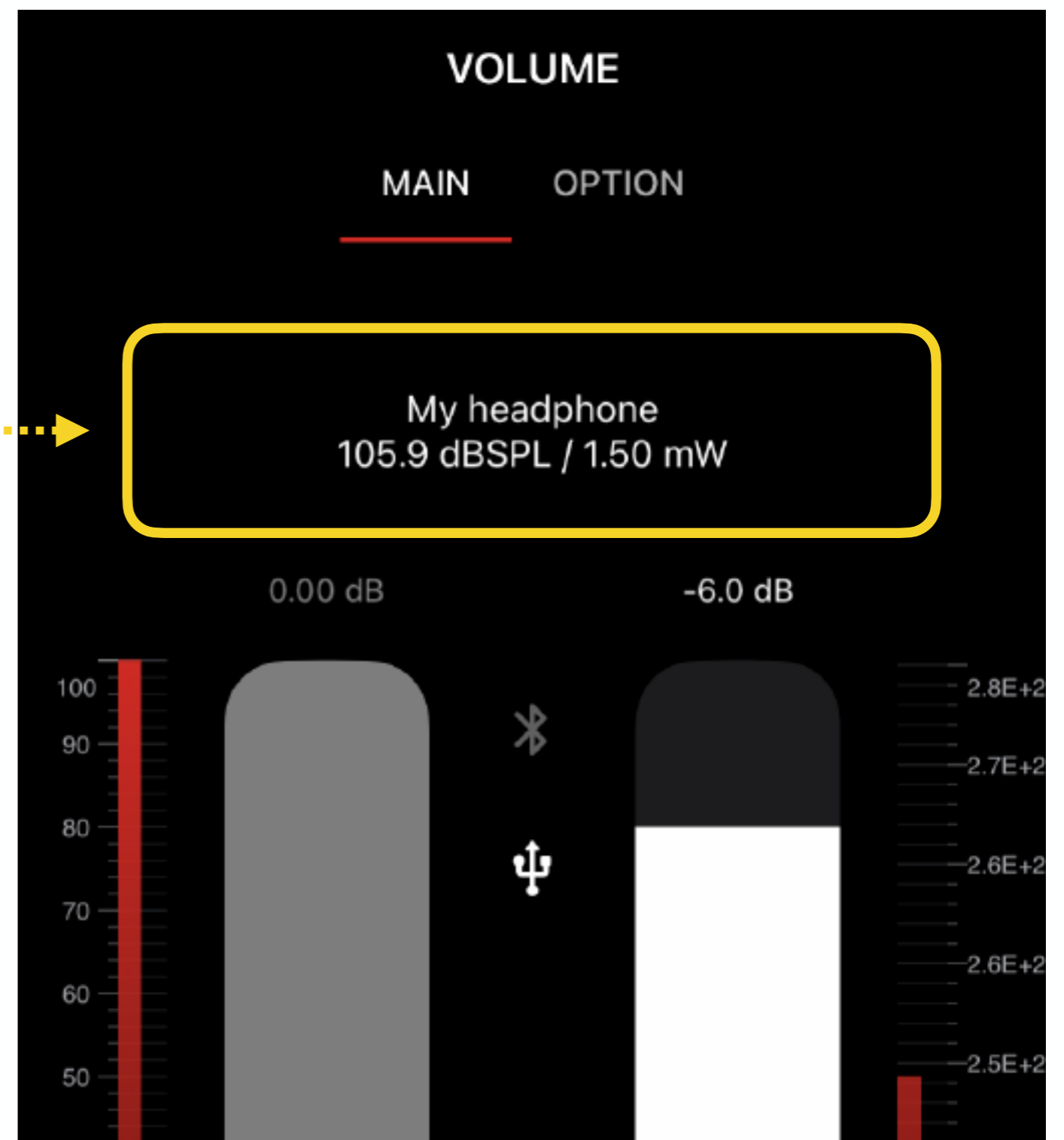
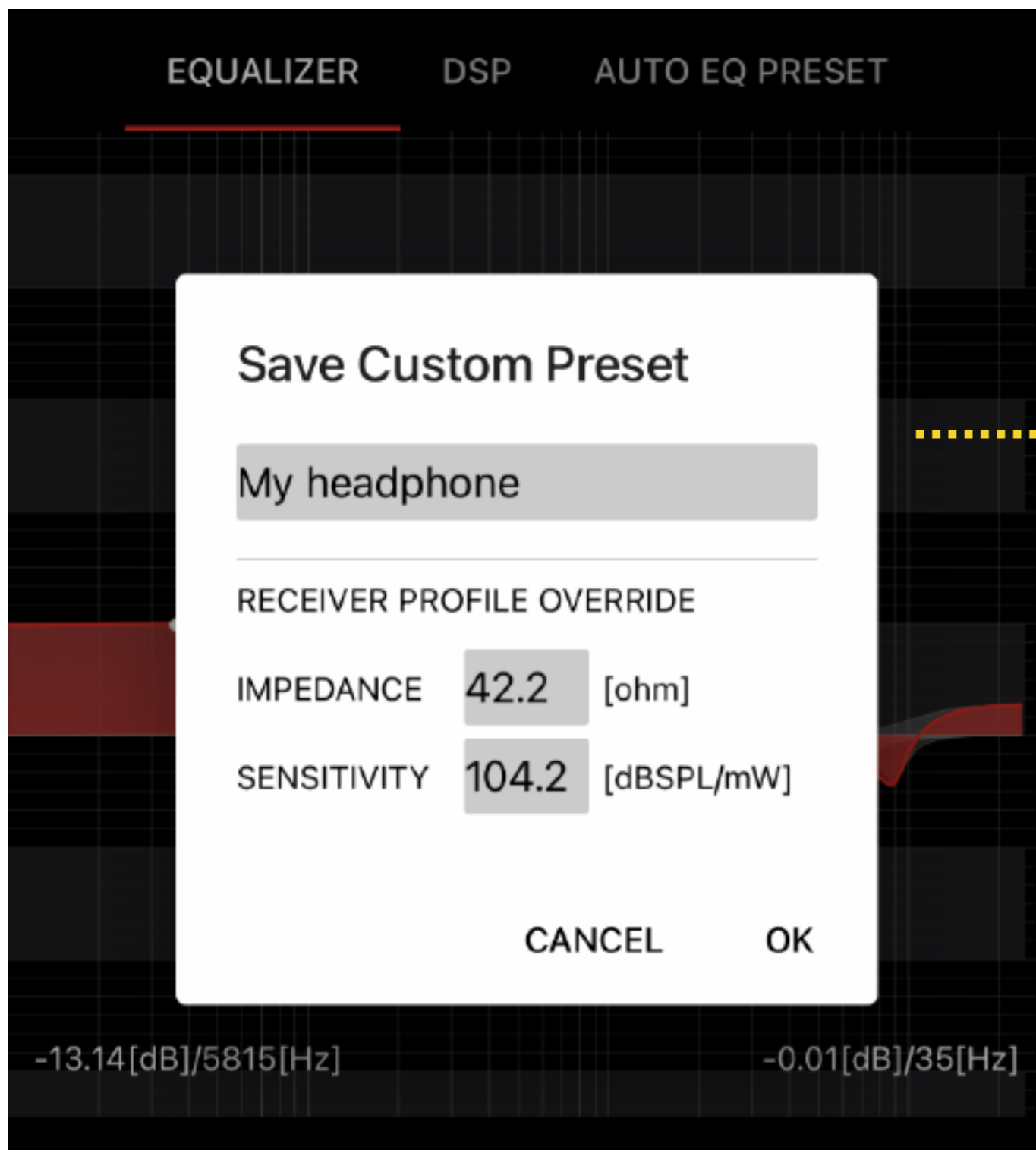

Mic. Pass-Thru Mode

- **MIC PASS-THRU mode**
 - Adjust Mic. Gain
 - Adjust the mix-up ratio with AMBIENT LEVEL slider
- **If ABSOLUTE VOLUME is ON,**
 - The smartphone side-key volume adjusts the overall 5K device volume.
 - The smartphone side-key volume adjusts both microphone and music at the current mix-up ratio.

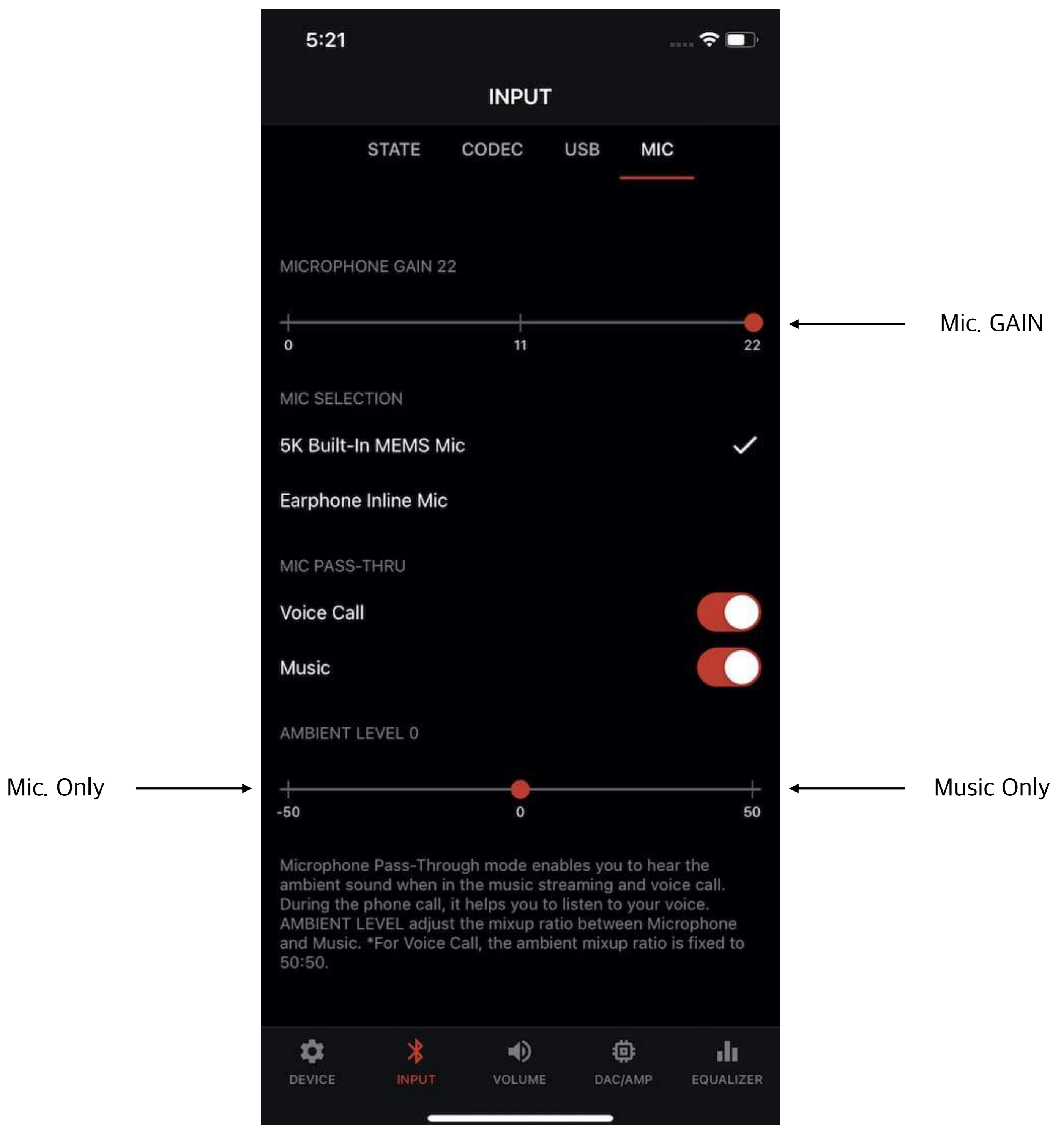

Antenna

High Sensitivity 3-dimensional LDS Antenna is printed on the bottom case and is placed around the red LED button. 5K provides the best RF performance in most use cases. However, for the optimal performance, please keep this area away from any metallic objects.

Bluetooth 2.4 GHz Class 2.5mW (4dBm)

3 Dimensional LDS (Laser Direct Structuring) Antenna



Warranty

- **One year warranty**
 - From the date of the first app connection
 - Automatically activated from the first connection with the companion mobile app
 - Any problem caused due to a defect in manufacturing will be repaired or replaced
 - The warranty is transferable and is not limited to the original purchaser
- **Warranty is managed upon Bluetooth MAC address and serial number**
 - No need to keep the proof of the purchase
 - No receipt nor invoice requires for the warranty service
- **Any issue caused by accident or misuse**
 - Can be replaced with a refurbished product at customer's charge & shipping fee
- **For any purchase from local distributors**
 - The respective distributor is responsible for the warranty and will handle the case directly
- **WARNING**
 - Warranty void if the case opened
 - DO NOT disassemble or open the case.
 - DO NOT use a high-speed charger. (Use a standard 5V charger or PC USB.)

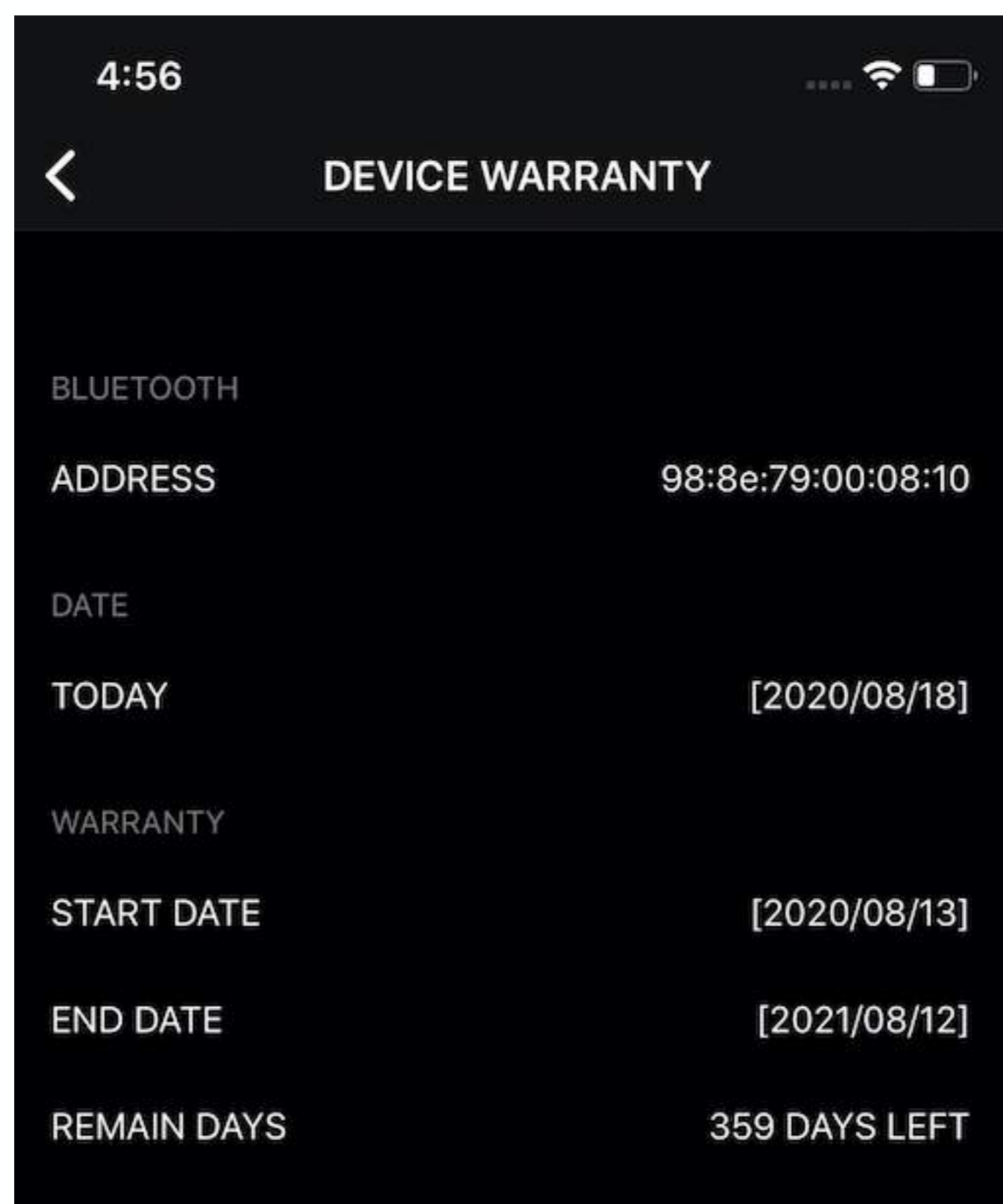

The screenshot shows a mobile application interface for 'DEVICE WARRANTY'. At the top, the time is 4:56 and there are icons for signal strength, Wi-Fi, and battery. A back arrow is on the left, and the title 'DEVICE WARRANTY' is in the center. Below the title, there are several sections of information:

BLUETOOTH	
ADDRESS	98:8e:79:00:08:10
DATE	
TODAY	[2020/08/18]
WARRANTY	
START DATE	[2020/08/13]
END DATE	[2021/08/12]
REMAIN DAYS	359 DAYS LEFT

Firmware Update - OTA

- **OTA(Over The Air) Firmware Update**
 - The app updates the 5K firmware over the Bluetooth link.
 - **UPDATE FIRMWARE vX.X.X** will appear when a new FW is available.
 - Please keep the 5K close to the smartphone during the FW update.
 - Until 5K receives and validates the perfect FW binary, it won't update the current FW.
 - If failed, please try it again.

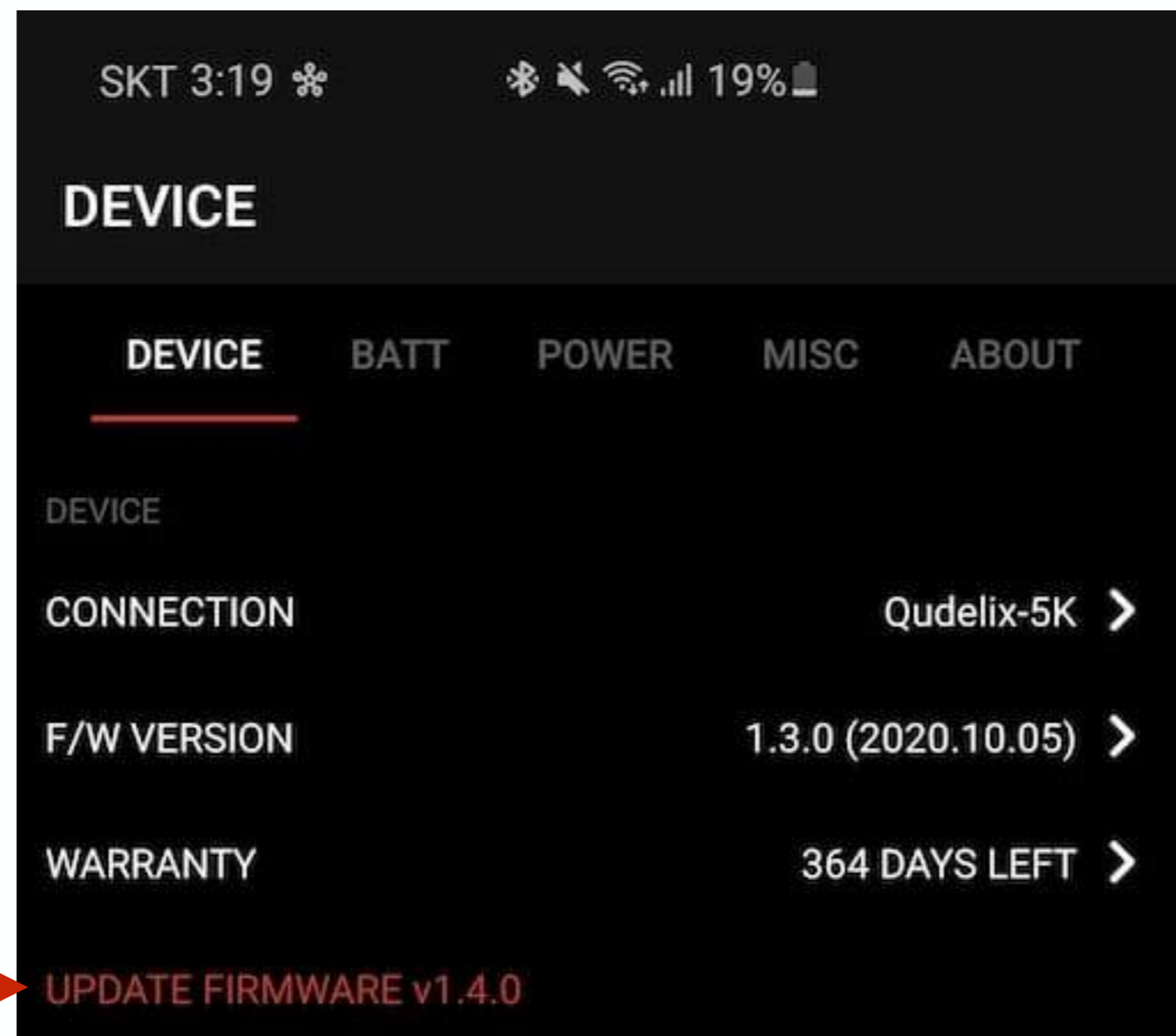

FW Update

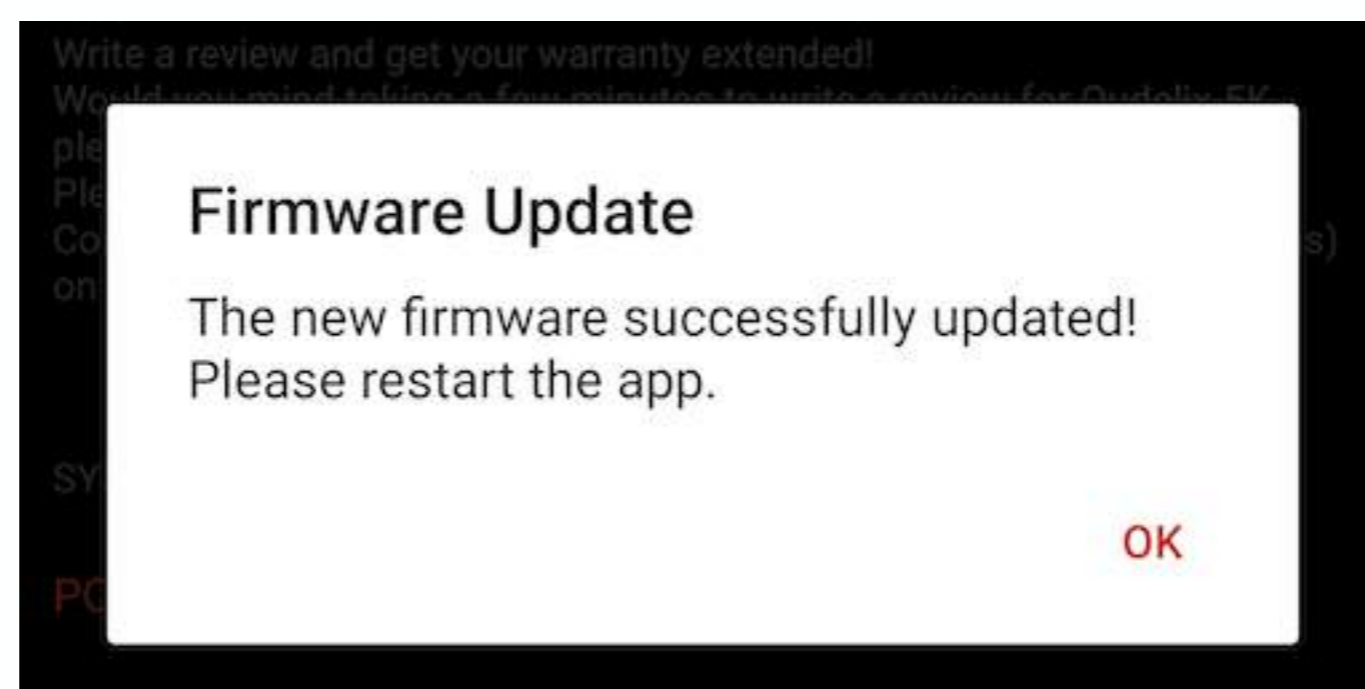
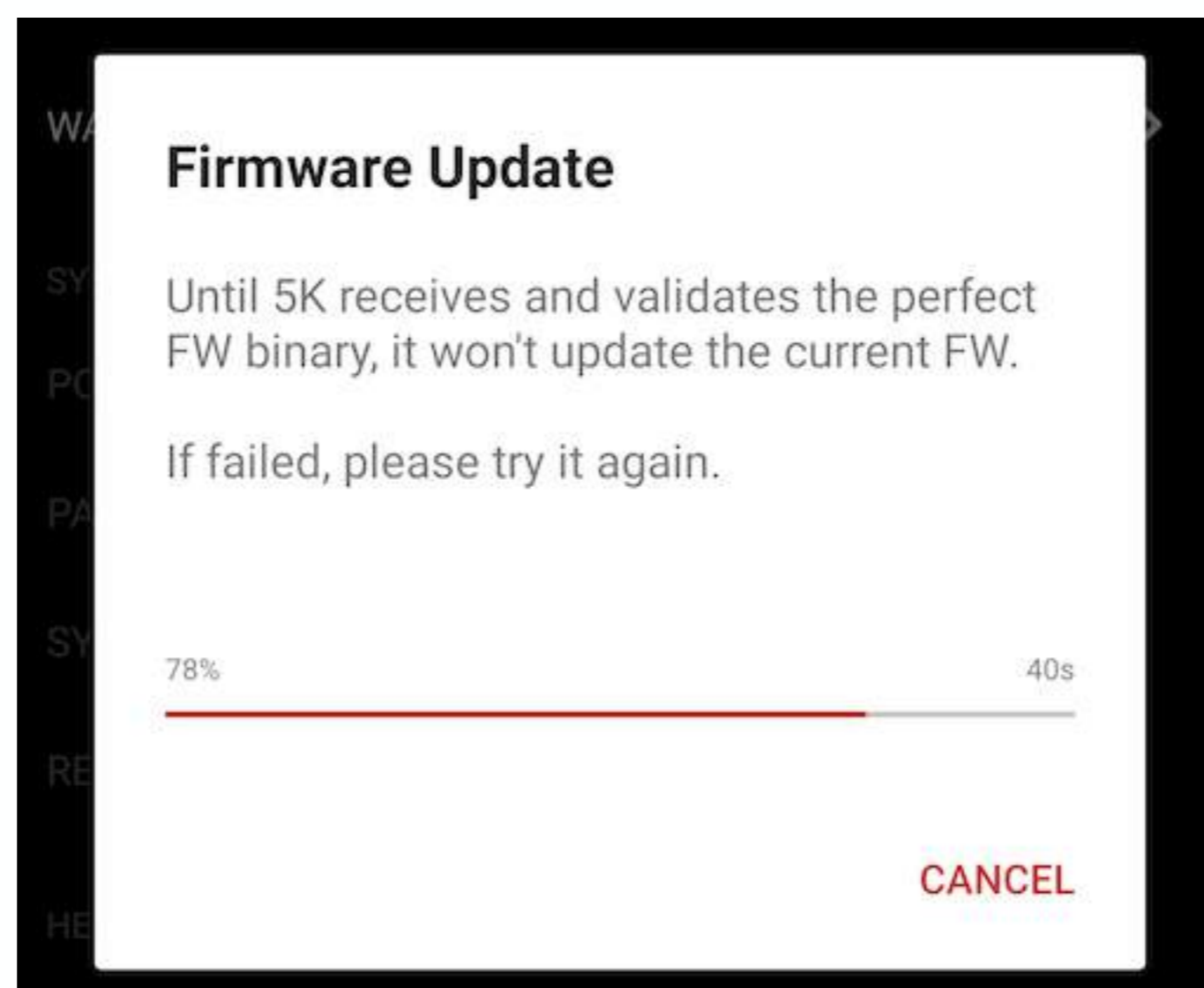

Qudelix Chrome Extension

- <https://chrome.google.com/webstore/detail/qudelix/phaodiidhofhdmfkjiacigibgikhfafn>
 - For a USB DAC use case with Windows, MacOS, and Linux, you can install the Qudelix Chrome Extension.
 - And You can simultaneously keep the app connections with a smartphone over Bluetooth and a PC over USB.
- *The Chrome app requires the 5K firmware version 1.12.0 or higher, please update the 5K device firmware first using the mobile app.

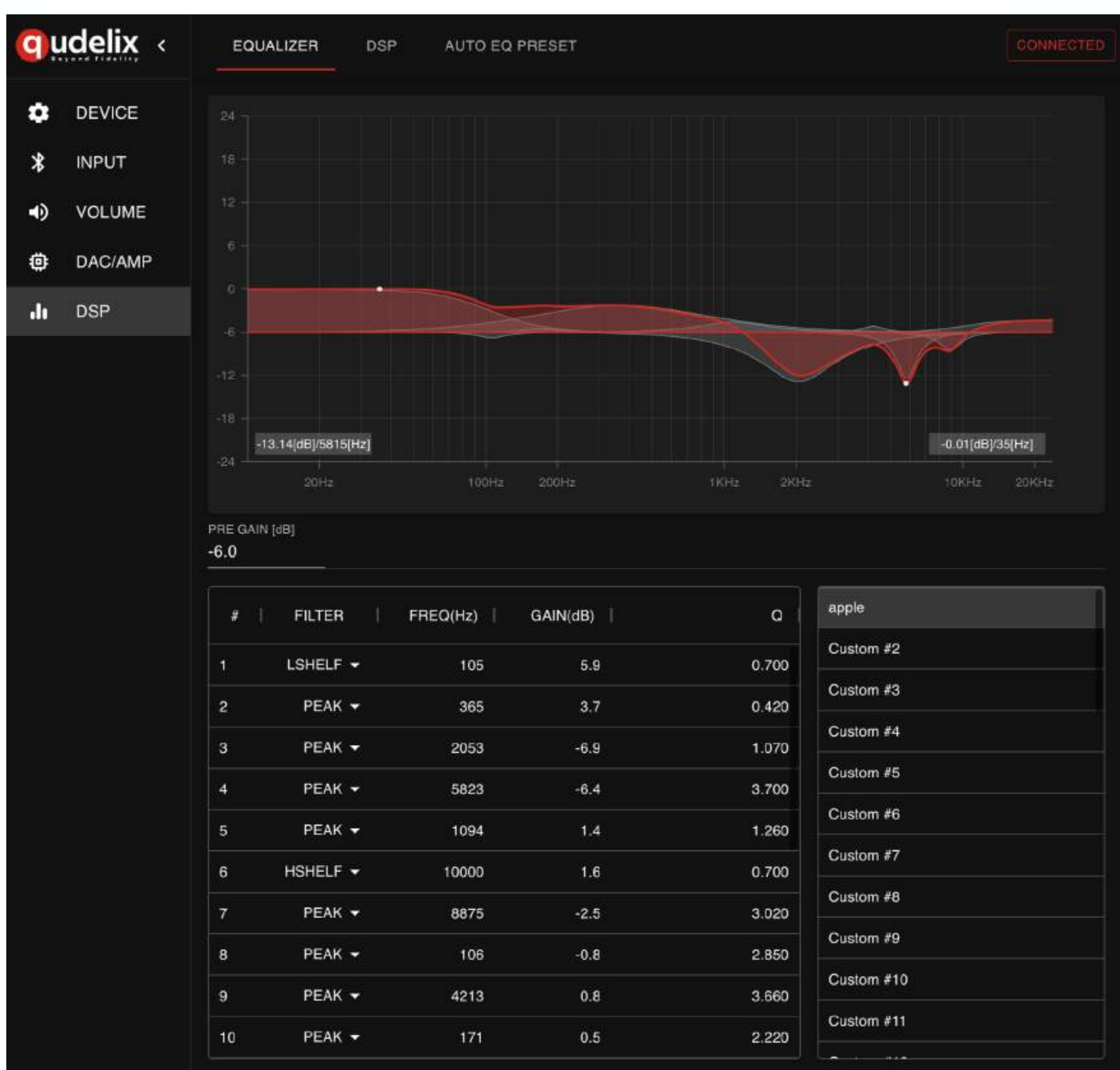

Appendix - PCBA

5K has three BGA(Ball Grid Array) IC parts; QCC5124, and two ES9128p.

To enhance the PCB reliability and durability, we did the epoxy underfills on those sensitive BGA parts, although having additional cost increase. Those parts are bonded twice with soldering and epoxy underfills.



Appendix - Size & Weight

Size

52.8(H) x 26.7(W) x 15.6(D) mm (including Clip)

Weight

25g



Appendix - Package

PACKAGE

91mm (L) x 55mm (W) x 55mm (H)

INCLUDED

USB C-to-C Cable (120mm)

USB C-to-A Cable (120mm)

*No User Manual included in the package. Please refer this user guide.



Appendix - Android Audio Output Device

- 5K Can be connected to Android both through Bluetooth and USB DAC (C-to-C) at the same time.
- In that case, the Android device detects multiple audio output devices. And the Android selects the active output device exclusively.
- *With some specific Android devices, **SONY Android App** sometimes overrides the system Audio Output selection to Bluetooth forcibly. If you don't get any sound through Android USB DAC, please try uninstalling SONY App.

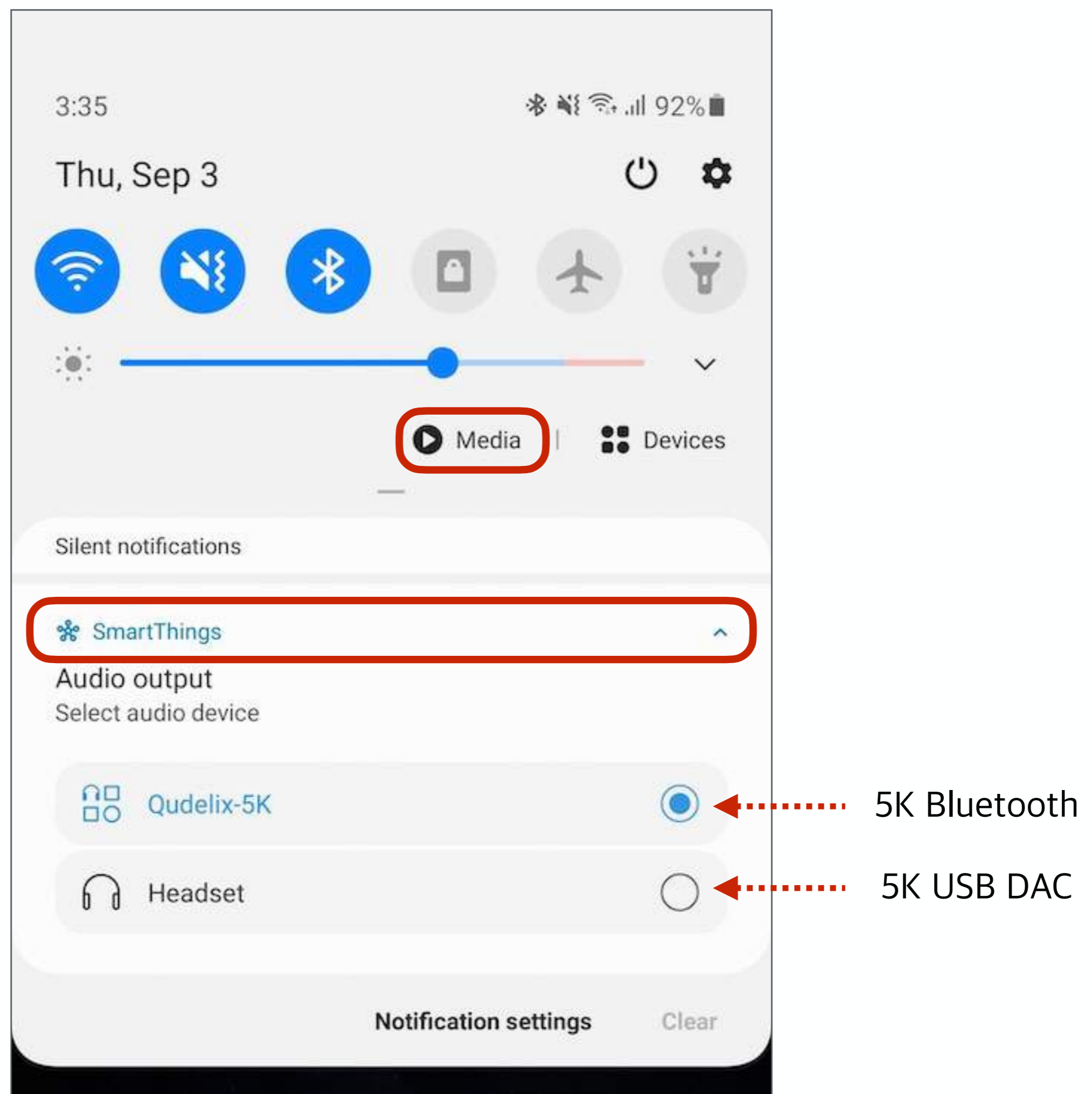

Android Audio Output Galaxy S10

Appendix - Android Audio Output Device

- In Android, Media → Audio Output, you can select the active device you want to use.
- The system menu for Audio Output may be different across smartphone manufacture.

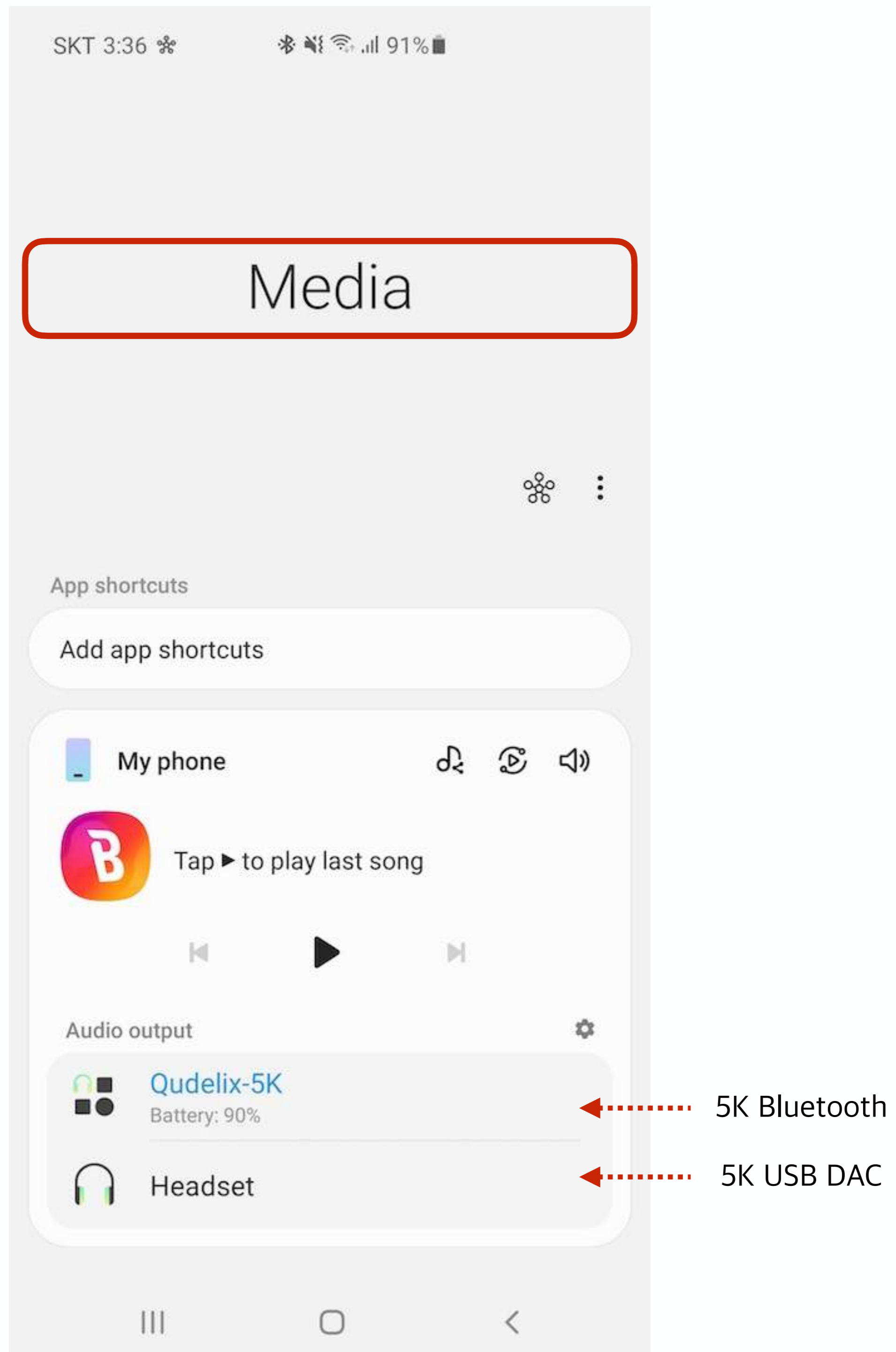

Android Audio Output Galaxy S10

Appendix - iOS Audio Output Device

- 5K Can be connected to iPhone both through Bluetooth and USB DAC (Apple Camera Kit) at the same time.
- In that case, the iPhone detects multiple audio output devices. And the iOS selects the active output device exclusively.

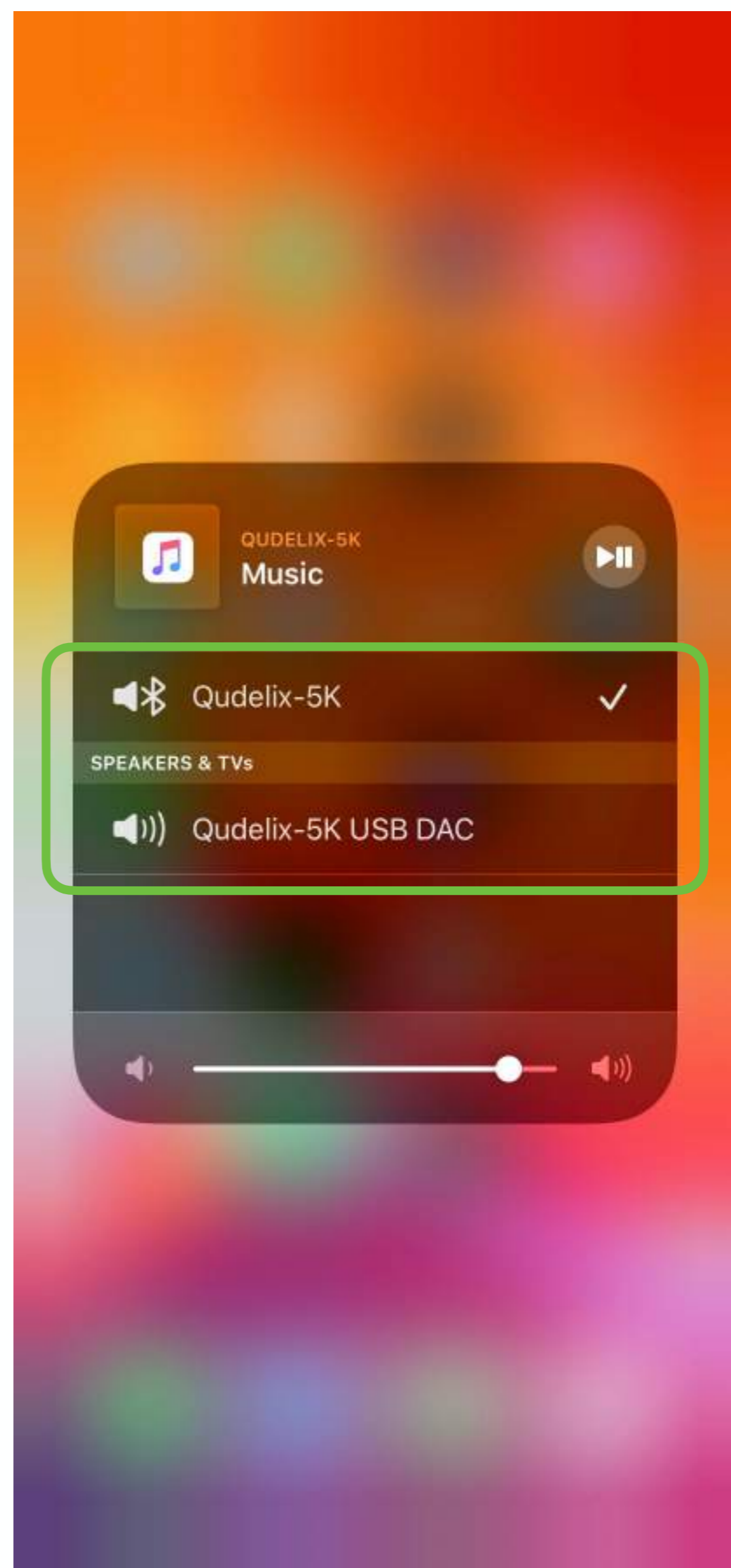
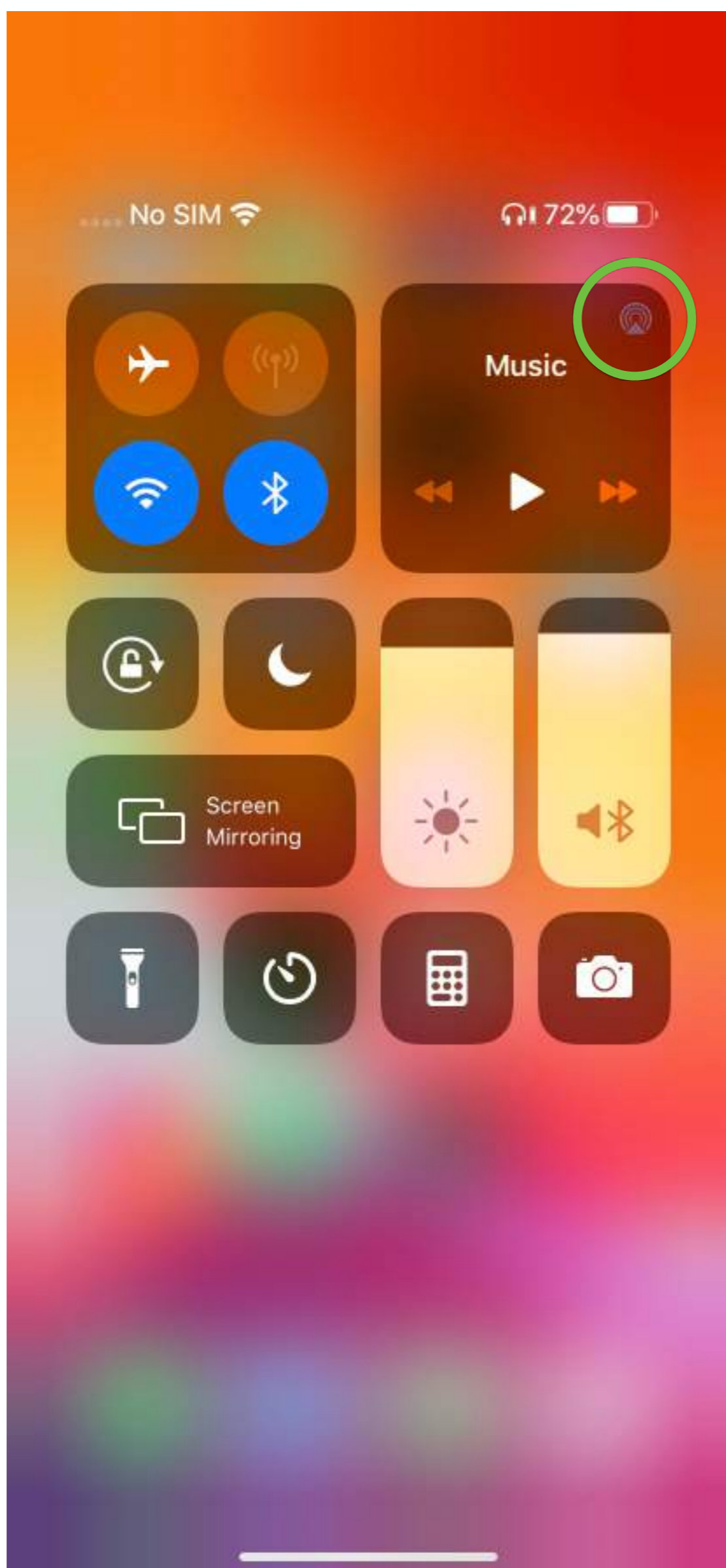

Appendix - Android In-Band Ringtone

- The way how the Bluetooth receiver plays the incoming call ringtone, Android OS selects.
- System Bluetooth → Option (Top Right) → Advanced → Ringtone sync

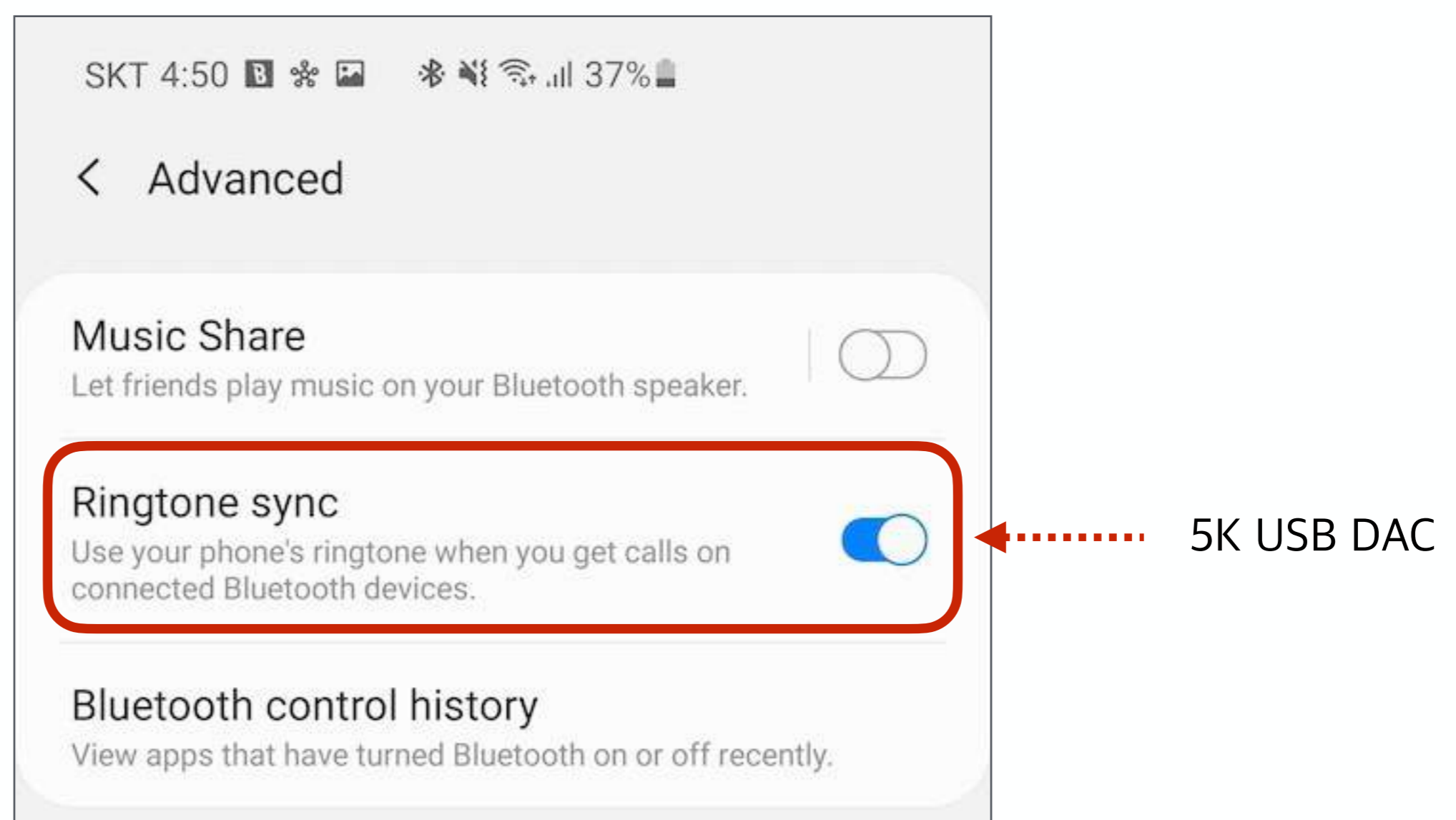
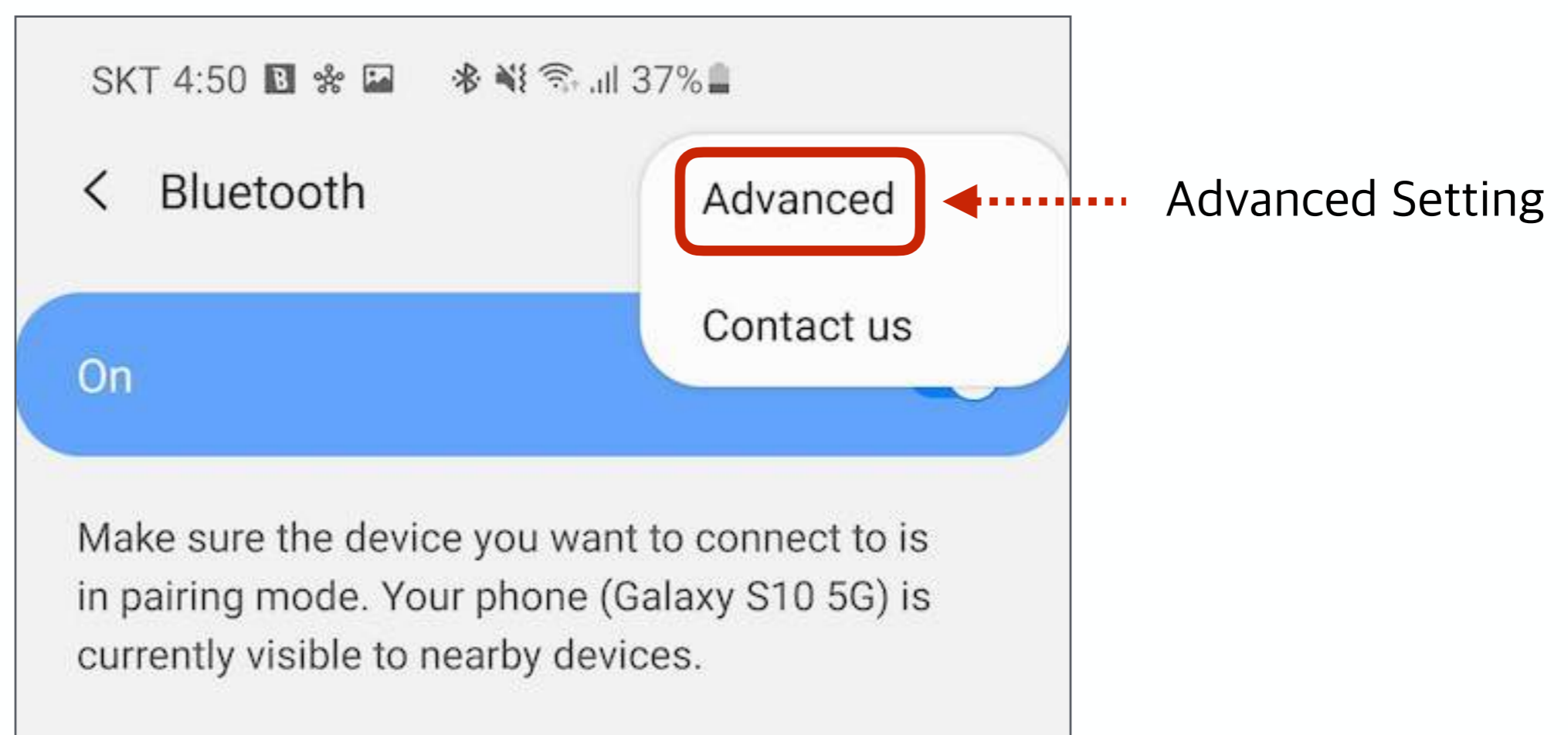
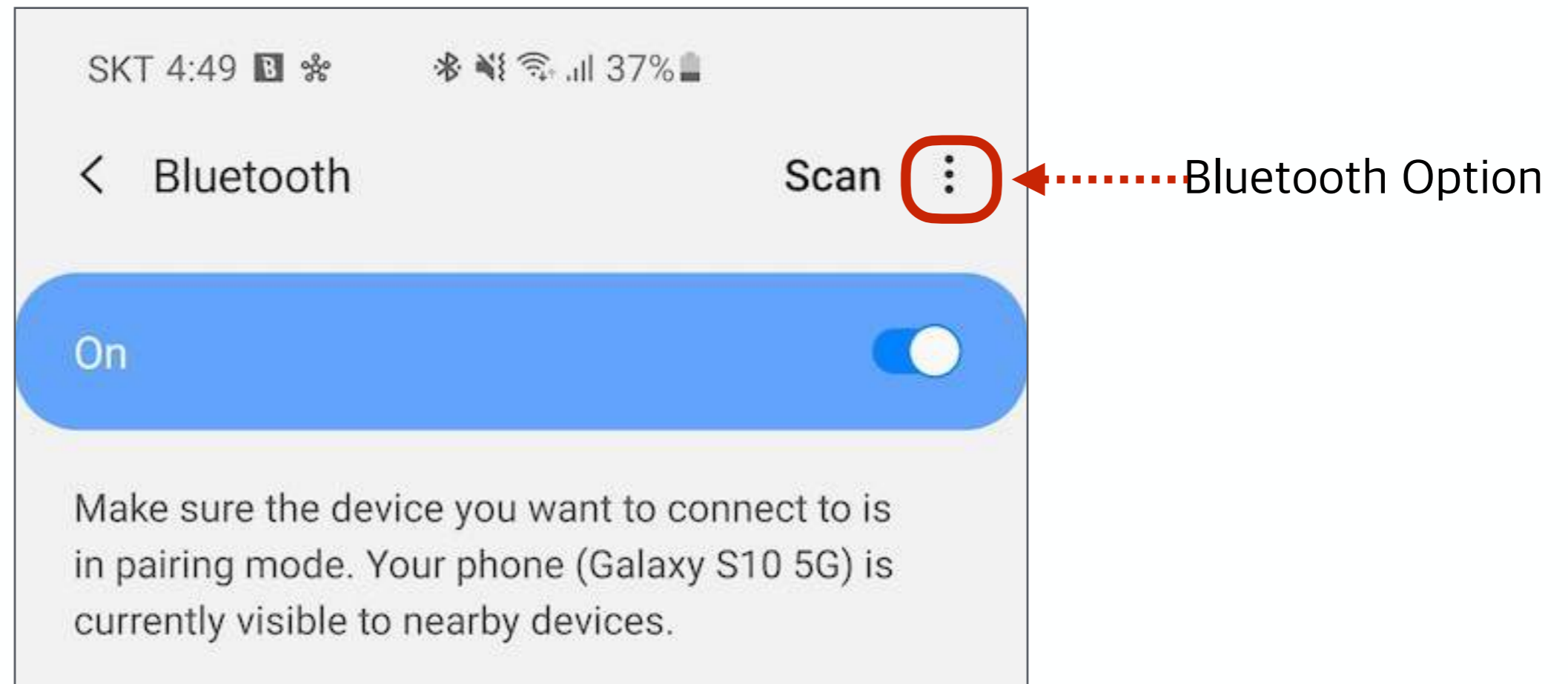

Android In-Band Ringtone Galaxy S10